

LC1214

AIR COMPRESSOR

LOW VOLTAGE



Images are for reference only

SPECIFICATIONS

Rated Voltage (s):	DC 12 Volts Pulsed
Voltage characteristic:	On 5ms, Off 15ms
Rated Pressure:	47 kPa
Rated Airflow:	1.5 l/min
Maximum Pressure:	>95kPa
Rated Frequency:	50Hz
Power Consumption Max (DC):	30 VA
Duty Cycle:	Continuous
Coil insulation Class:	Class F
Environmental Conditions:	0°C - 40°C & 35% - 85% RH
Mounting Dimensions:	48(L) x 62(W) mm
Unit outside dimensions:	90mm x 58mm x 58mm
Gross Weight:	700grams (1.54lbs)
Lead Wire Length:*	AWG22 (UL1015, 105°C) X 260mm
Outlet:*	7.5mm diameter bard, hose elbow nipple.

*Example given. Customer determined attributes are available.
Patented and patents pending

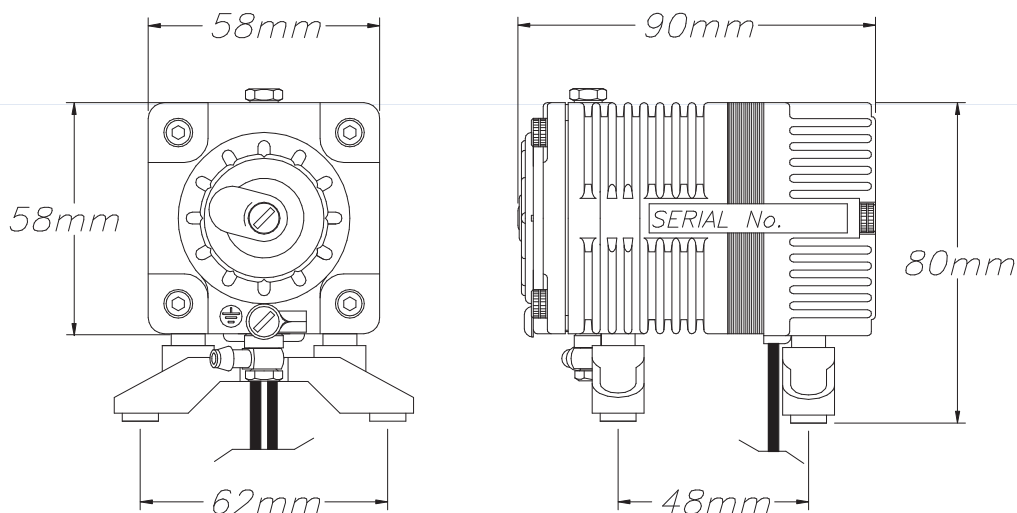
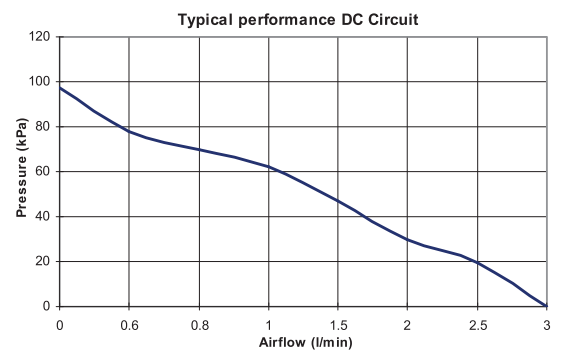

Contact technical sales for additional information regarding life expectancy and operating conditions.
All the information in this datasheet is supplied in good Faith.
This information is given without obligation or liability.