



PLT-UN25F is a high-efficiency, general-purpose cold plate for thermal applications such as TEC, LED, image sensor, and semiconductor cooling. The active cooling area is 25mm x 25mm (0.98in x 0.98in), and it utilizes a 0.5mm microfin internal structure.

One loose steel bracket is included, designed for easy fabrication and modification (see dimensions under the "Files" tab). The included bracket accommodates diagonal mounting hole distances from approximately 60mm to 88mm (2.36in to 3.46in).

Cold plate materials include copper, a brass top, anti-corrosive nickel plating, and EPDM o-ring. Threaded for G 1/4 BSPP fittings.

Cold Plates	
Flow Resistance @ 5LPM (10-13mm ID)	0.077 kgf/cm <sup>2</sup> (1.1psi)
Thermal Resistance @ 5LPM (Approx.)	0.047°C/W
General	
Weight	0.28 lb (0.13 kg)
Fitting Thread	G 1/4 BSPP
Materials	Nickel-Plated Copper, Nickel-Plated Brass, EPDM
Max Pressure @ 25°C	8kgf/cm <sup>2</sup> (113.8psi)
Max Temperature	100°C (212°F)

PLT-UN25F

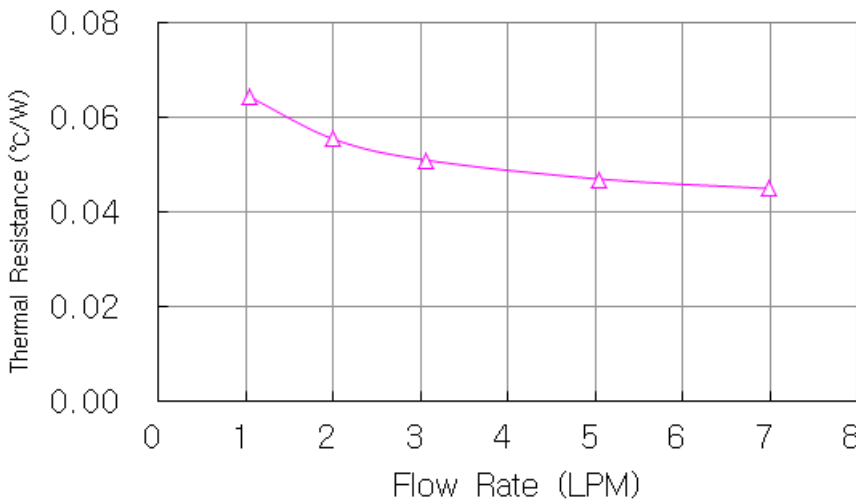

PLT-UN xx F

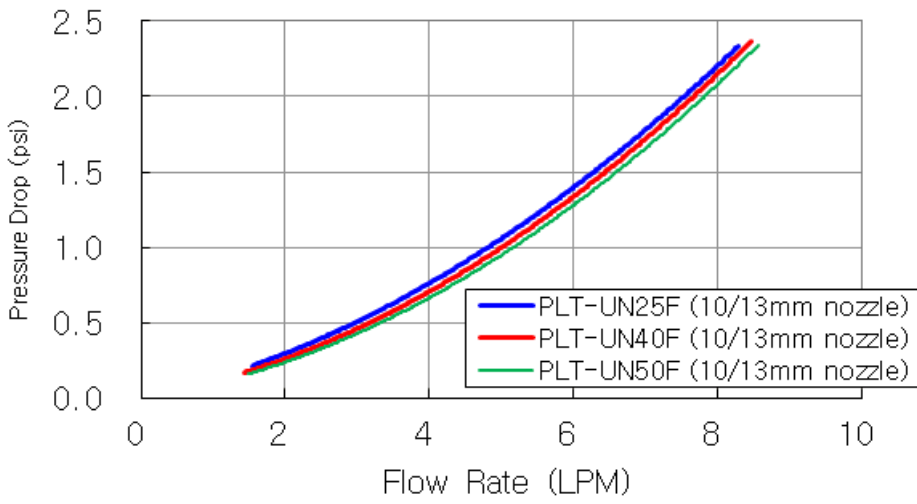

PLT-UNxxF

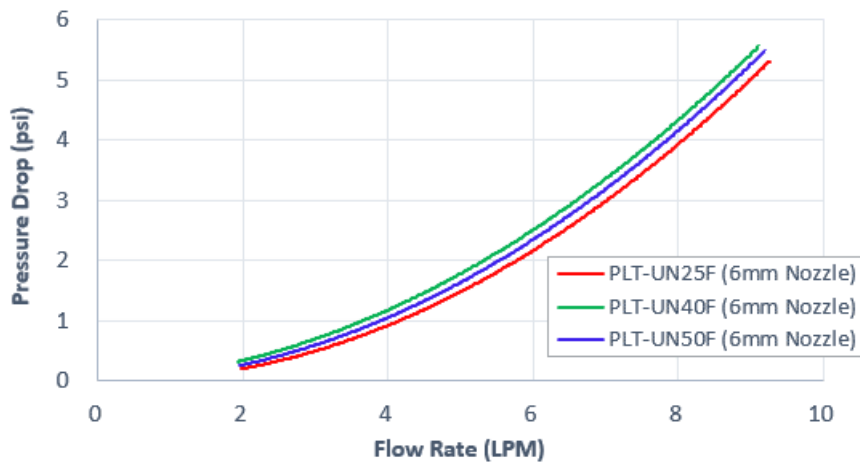

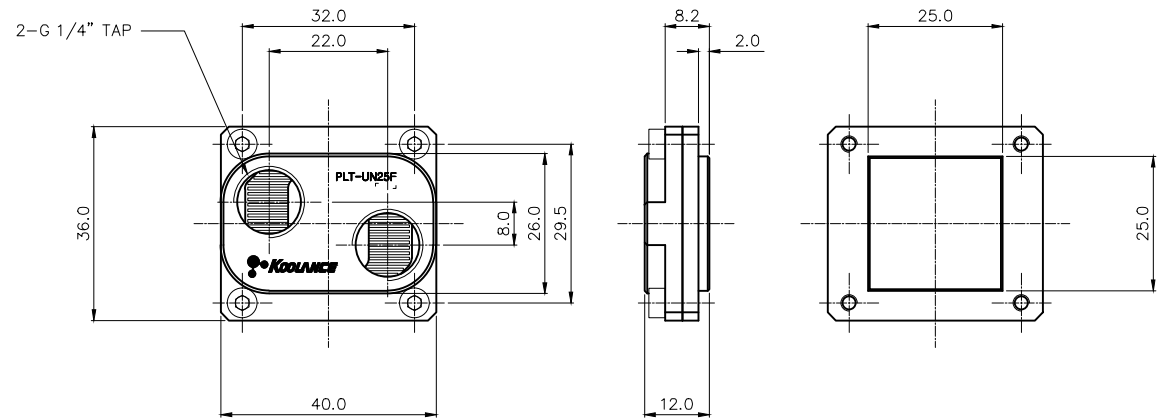
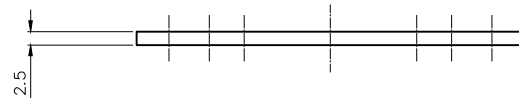
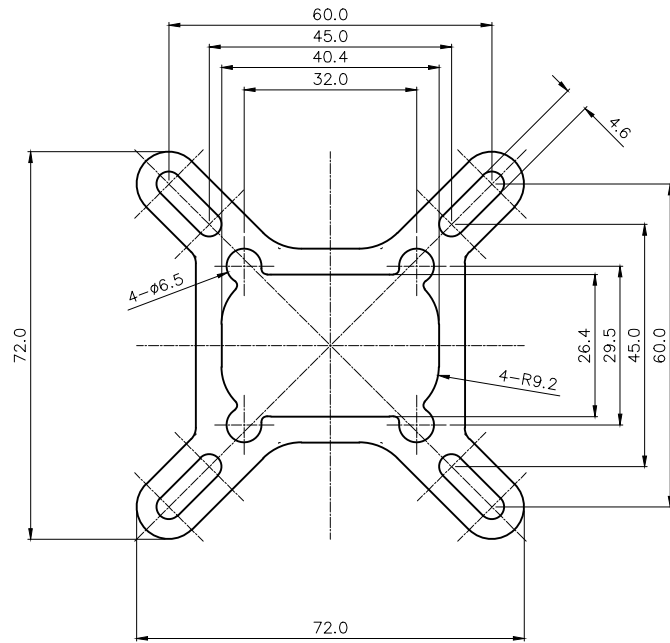

REV	DATE	CONTENTS	REVD BY	CHKD BY	APPD BY
REVISION					

NO.	DESCRIPTION				MATER'L		QUANTITY	REMARKS
<b>KOOLANCE INC.</b>					UNIT	MM	ITEM	PLT-UN25F
					SCALE	N/S	TITLE	
					Ass'y			
DATE	BY	BY	BY	APPRO BY	3RD ANGLE			
					CODE NO.	DWG. NO.		PAGE