

AP1024-B

VACUUMPUMP

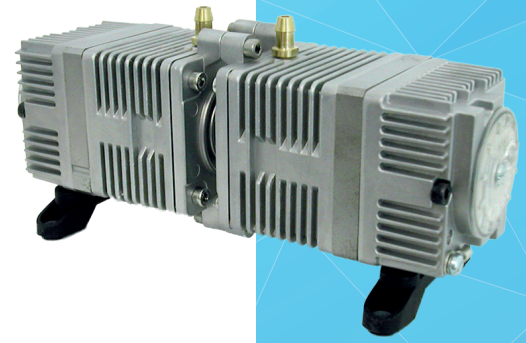

Images are for reference only

SPECIFICATIONS

SERIES CONFIGURATION

Rated Vacuum:	-20 kPa (-200mB, 5.91inHg)
Maximum Vacuum Airflow:	12 l/min (0.42cfm)
Maximum Vacuum:	-71.0 kPa (-710mB, -20.98inHg)

PARALLEL CONFIGURATION

Rated Vacuum:	-17.6 kPa (-176mB, -5.2inHg)
Maximum Vacuum Airflow:	24 l/min (0.84cfm)
Maximum Vacuum:	-35 kPa (-350mB, -10.34inHg)

FEATURES OF BOTH CONFIGURATION

Rated voltage(s):	100V, 120V, or 230V
Rated Frequency:	50Hz or 60Hz
Power Consumption:	23-27 Watts
Duty Cycle:	Continuous
Coil insulation Class:	Class F. Class B for UL (1450) (120V)
Noise Level:	45 dB (A)
Environmental Conditions:	0°C - 40°C & 35% - 85% RH
Mounting Dimensions:	146(L) x 62(W) mm
Unit outside dimensions:	216mm x 58mm x 58mm
Gross Weight:	700grams (1.54lbs)
Lead Wire Length:*	260mm Standard
Outlet:*	7.5mm diameter bard, hose nipple.

*Example given. Customer determined attributes are available. Patented and patents pending

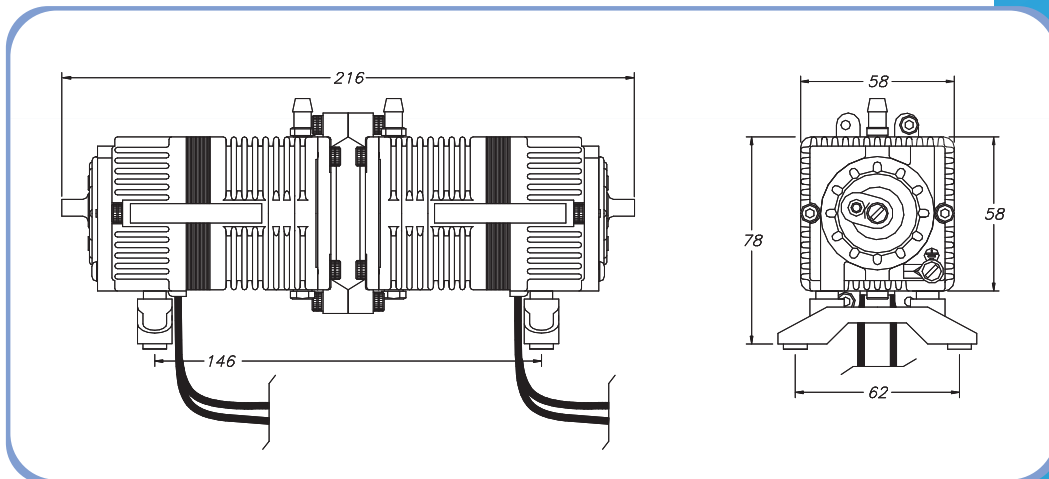
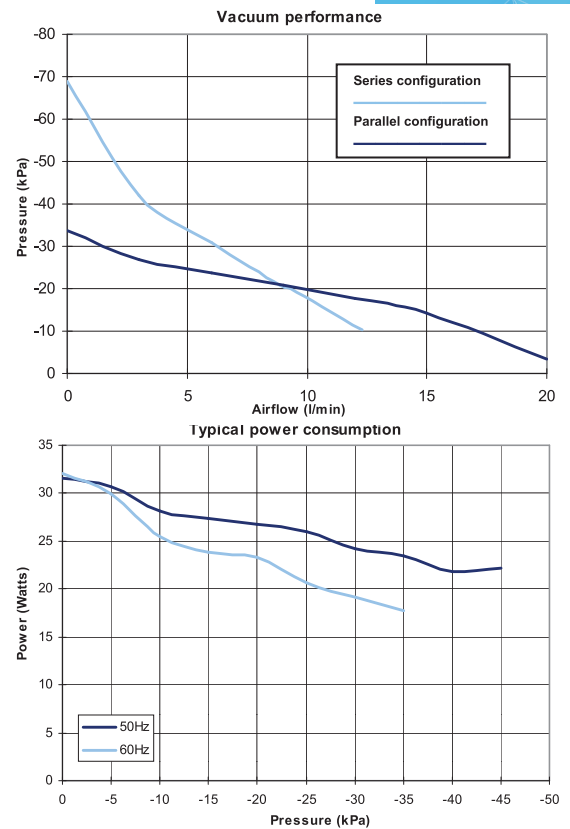

Contact technical sales for additional information regarding life expectancy and operating conditions.

All the information in this datasheet is supplied in good faith.

This information is given without obligation or liability.