

AC1016

AIR COMPRESSOR



SPECIFICATIONS

Rated Pressure:	50kPa (500 mB, 7.24psi)
Rated Airflow:	>2.5 l/min (0.88cfm)
Rated Voltage (s):	230V
Maximum Pressure:	>95 kPa (950mB, 13.75psi)
Rated Frequency:	50Hz
Power Consumption:	14-15 Watts
Duty Cycle:	Continuous
Coil insulation Class:	Class F. Class B for UL (1450) (120V)
Noise Level:	Below 40 dB (A)
Environmental Conditions:	0°C - 40°C & 35% - 85% RH
Mounting Dimensions:	48(L) x 62(W) mm
Unit outside dimensions:	90mm x 58mm x 58mm
Gross Weight:	700grams (1.54lbs)
Lead Wire Length:*	AWG22 (UL1015, 105°C) X 260mm
Outlet:*	7.5mm diameter bard, hose nipple.

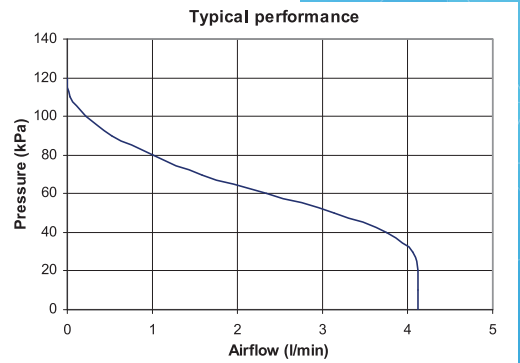

*Example given. Customer determined attributes are available.
Patented and patents pending

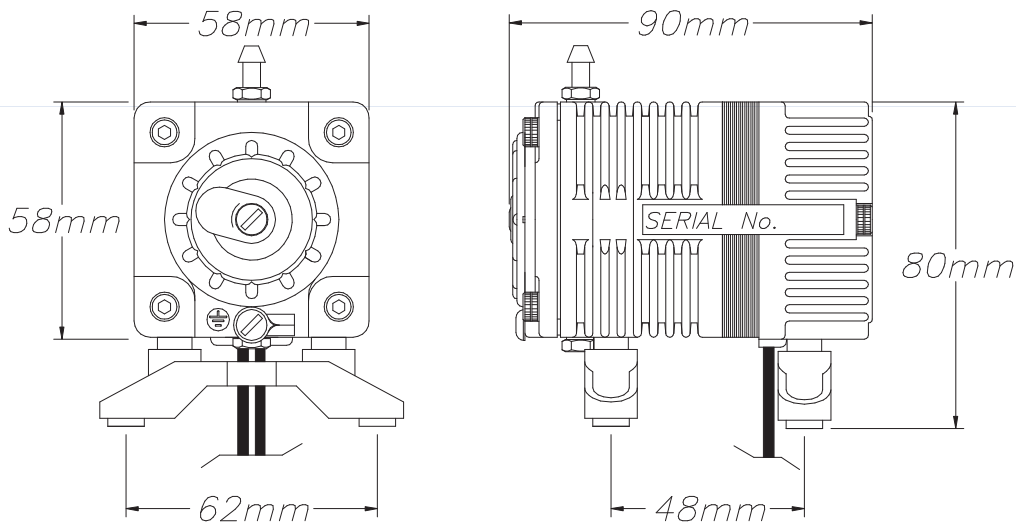

Contact technical sales for additional information regarding life expectancy and operating conditions.
All the information in this datasheet is supplied in good Faith.
This information is given without obligation or liability.