

W911



STEEL INDEXING PLUNGER WITH LONG NOSE PIN AND LOCK NUT

Materials:

(3) Stainless steel spring (Aisi 301).

W911:

(2) Threaded high-resistance steel hexagon ring nut.

(1) Hardened high resistance steel plunger pin.

(4) Threaded steel lock nut (UNI 5589).

W911CIN:

(2) Threaded stainless steel hexagon ring nut (Aisi 303).

(1) Stainless steel plunger pin (Aisi 303).

(4) Threaded stainless steel lock nut (Aisi 304) (UNI 5589).

Surface finish:

Smooth.

Colour:

W911: Black-oxide treated.

W911CIN: Natural.

ATTENTION:

- > We recommend an H7 tolerance for the plunger stem bore.
- > The nut is supplied assembled.

Special Requests:

- On request the nut can be supplied disassembled.

Note:

This plunger version can be coupled with any hanwheel with threaded insert, to be ordered separately (see additional pictures).

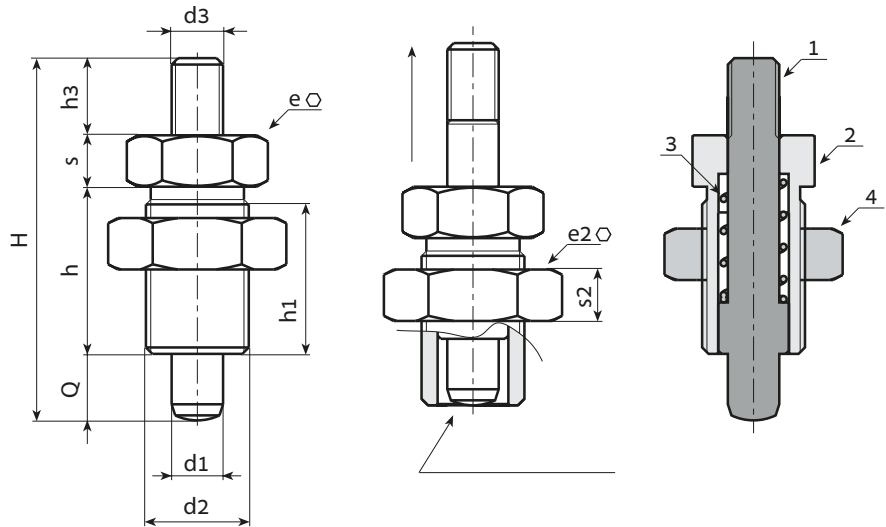

Version W911 - black-oxide treated steel

Stock availability as % (🛒)
90% (●) - 40% (●) - 5% (●)

🛒	Art.	H	h	h1	d2	d3	h3	e	s	e2	s2	d1 -0,02 -0,04	Q	g
●	W911010.Q05X08	36	17	15	M10x1	M04	6	12	5	17	6	5	8	20
●	W911012.Q06X09	45	20	18	M12x1,5	M05	10	14	6	19	7	6	9	32
●	W911016.Q08X12	58	26	23	M16x1,5	M08	12	19	8	24	8	8	12	62
●	W911016.Q10X12	58	26	23	M16x1,5	M08	12	19	8	24	8	10	12	63
●	W911020.Q12X15	70	33	30	M20x1,5	M10	12	22	10	30	9	12	15	134

Version W911 CIN - stainless steel (Aisi 303)



🛒	Art.	H	h	h1	d2	d3	h3	e	s	e2	s2	d1 -0,02 -0,04	Q	g
●	W911010.I05X08CIN	36	17	15	M10x1	M04	6	12	5	17	6	5	8	20
●	W911012.I06X09CIN	45	20	18	M12x1,5	M05	10	14	6	19	7	6	9	32
●	W911016.I08X12CIN	58	26	23	M16x1,5	M08	12	19	8	24	8	8	12	62
●	W911016.I10X12CIN	58	26	23	M16x1,5	M08	12	19	8	24	8	10	12	63
●	W911020.I12X15CIN	70	33	30	M20x1,5	M10	12	22	10	30	9	12	15	134

