

W790



KNOB WITH BLACK OXIDE TREATED STEEL PLUNGER AND FLANGE

Materials:

(3) Reinforced polyamide lobed knob. Cannot be disassembled.
Resistant to oils and greases.

Surface finish:

(3) Satin.
(1-2) Smooth.

Colour:

(3) Black (RAL 9011).
(1-2) Black-oxide treated.

Inserts:

(4) Stainless steel spring.
(1) Smooth steel body, with incorporated turned and bored flange.
(2) Hardened high resistance steel plunger pin.

ATTENTION:

> We recommend an H7 tolerance for the plunger stem bore.

Special Requests:

• On request and for special quantities the knob can be supplied in the colours indicated in the table [page].

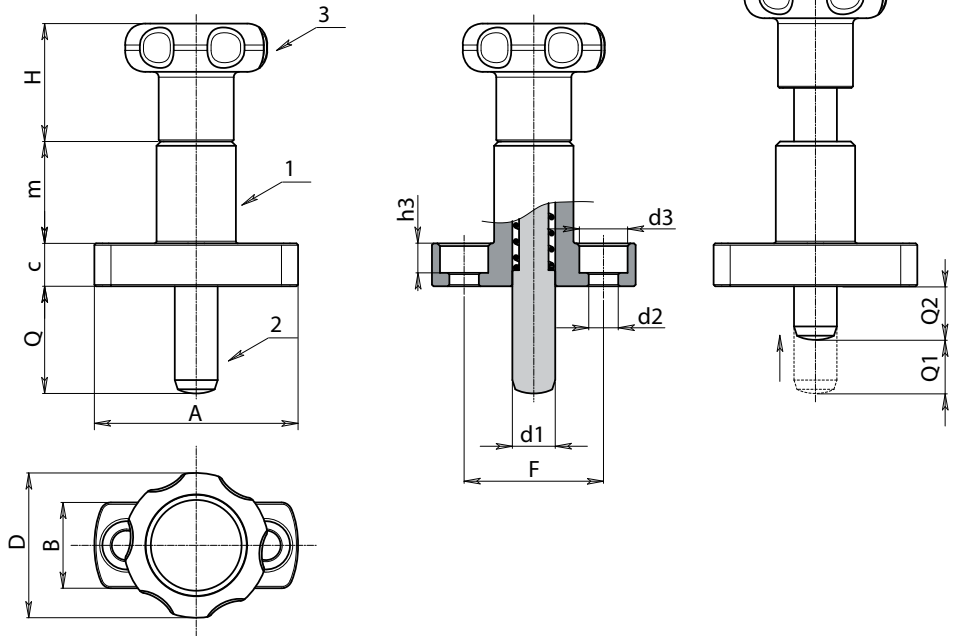

Stock availability as % (🛒)
90% (●) - 40% (●) - 5% (●)

🛒	Art.	D	H	m	c	A	B	F	h3	d2	d3	d1 -0,02 -0,04	Q	Q1	Q2	📦
●	W790027.Q08X2001	27	22	19	8	38	16	26	5.5	5.5	9	8	20	10	10	74
●	W790027.Q08X2601	27	22	19	8	38	16	26	5.5	5.5	9	8	26	10	16	75
●	W790027.Q10X2401	27	22	19	8	38	16	26	5.5	5.5	9	10	24	12	12	75
●	W790027.Q10X3201	27	22	19	8	38	16	26	5.5	5.5	9	10	32	12	20	76

Arbel Agencies LTD.



11 Ba'alei Hamelacha st. Qiryat Bialik P.O.B 1095, ZIP 2751311, ISRAEL
+972(0)48736969 ☎ +972(0)48730708 📠 info@arbel-ltd.com 📧 www.arbel-ltd.com 🌐

