

# R604

**NEW**



## POLYPROPYLENE / RUBBER WHEEL WITH ROUND STEEL SWIVEL SUPPORT AND THREADED STUD WITH BRAKE

### Materials:

#### Wheel body:

Polypropylene.

#### Tread:

Synthetic thermoplastic rubber. Hardness 93 ± 3 Shore A.

### Surface finish:

Smooth.

### Colour:

- (1) Dark grey.
- (2) Light grey.
- (3-4-5-6-7) Galvanised blue.

### Wheel rotation (4):

The hole for the pivot pin is formed by plastic moulding. A galvanised steel tube is positioned between the stud and the hole for protection.

### Bracket (3):

Steel fork (DD13), with integrated brake. Brake actuation lever moulded in grey plastic.

### Rotating assembly (5):

Steel rotating assembly with double ball race and threaded stud (thread tolerance 6g).

### Wheel fastening (6):

Steel hex head screw, coupled with a steel nut.

### Special requests:

- With a minimum of 100 pieces, M12 threaded studs can be supplied instead of M10, and vice versa.
- Upon request the wheel can be supplied in material with high electrical conductivity (ESD).

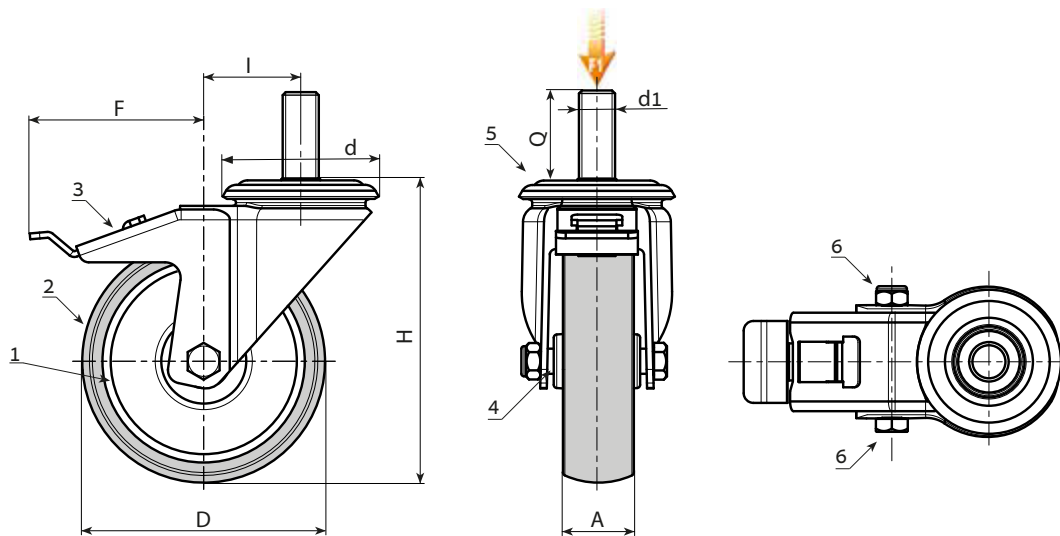

Version: standard.

Stock availability as % (🛒)  
90% (●) - 40% (●) - 5% (●)

art.	D	A	H	I	d	F	d16g	Q	g	F1 (Kg)
R604050.T18M10X25	50	18	70	26	48	80	M10	25	-	40
R604063.T22M10X25	63	22	90	26	48	84	M10	25	-	60
R604080.T22M10X25	80	22	109	25	48	84	M10	25	-	60
R604100.T27M12X30	100	27	134	36	57	106	M12	30	-	80
R604125.T27M12X30	125	27	159	35	57	106	M12	30	-	80

Version ESD: with wheel in conductive material.



art.	D	A	H	I	d	F	d16g	Q	g	F1 (Kg)
R604050.T18M10X25ESD	50	18	70	26	48	80	M10	25	-	40
R604060.T22M10X25ESD	60	22	90	26	48	84	M10	25	-	60
R604080.T24M10X25ESD	80	24	109	25	48	84	M10	25	-	60
R604100.T29M12X30ESD	100	29	134	36	57	106	M12	30	-	80
R604125.T29M12X30ESD	125	29	159	35	57	106	M12	30	-	80



Arbel Agencies LTD.  
 11 Ba'alei Hamelacha st. Qiryat Bialik P.O.B 1095, ZIP 2751311, ISRAEL  
 +972(0)48736969 ☎ +972(0)48730708 📠 info@arbel-ltd.com 📧 www.arbel-ltd.com 🌐

