

# R302



## SHEET METAL RIM / RUBBER WHEEL WITH ROUND STEEL SWIVEL SUPPORT AND SMOOTH THROUGH HOLE WITH BRAKE

### Materials:

#### Wheel body:

Two stamped sheet metal disks (steel DD13) riveted together to create a single body.

#### Tread:

Natural rubber trapezoidal tread. Hardness  $85 \pm 4$  Shore A.

#### Surface finish:

Smooth.

#### Colour:

(2) Black (RAL 9011).

(1-3-4-5-6) Galvanised blue.

#### Wheel rotation:

The hole for the pivot pin is stamped in sheet metal. A black polyamide insert is positioned between the pin and the hole for protection.

#### Bracket (3):

Steel fork (DD13), with integrated brake.

#### Rotating assembly (5):

Steel rotating assembly with double ball race and smooth fixing hole, (hole tolerance H7).

#### Wheel fastening (6):

Steel hex head screw, coupled with a steel nut.

#### Special requests:

- Upon request and for a minimum of 20 pieces, the wheel can be supplied with a needle roller cage, (replace code no. R302 with code no. R332).

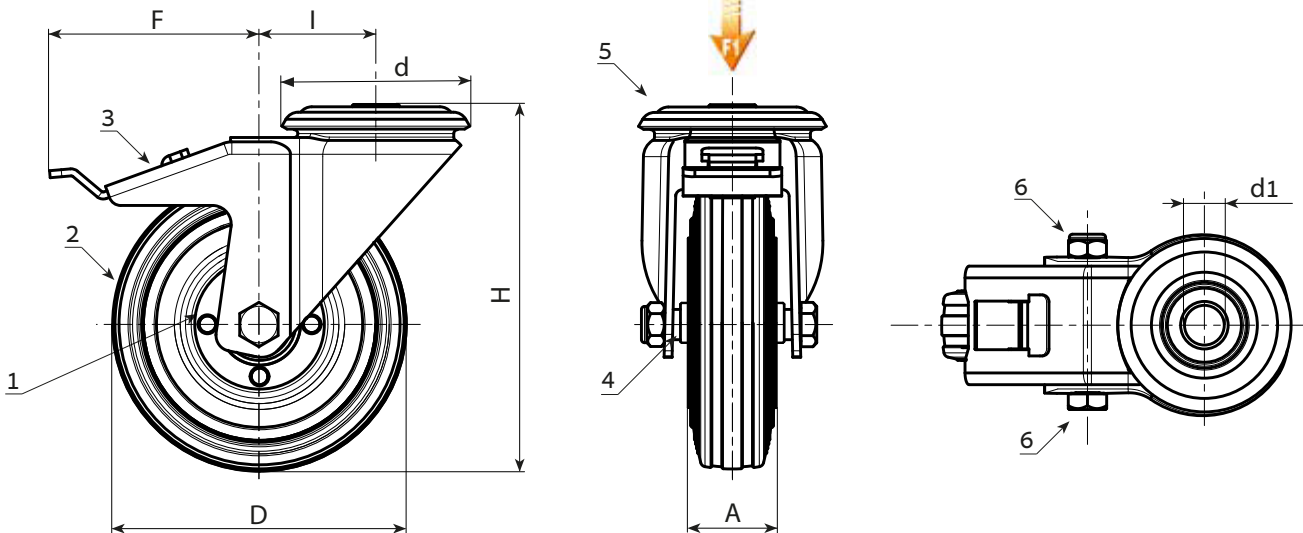

Stock availability as % (🛒)  
90% (●) - 40% (●) - 5% (●)

🛒	art.	D	A	H	I	d	d1H7	F	g	F1 (Kg)
●	R302080.T25D12	80	25	108	32	64	12	110	570	50
●	R302100.T30D12	100	30	127	32	64	12	110	618	70
●	R302125.T37D12	125	37.5	155	32	64	12	113	1134	100
●	R302150.T37D12	150	37.5	183	35	65	12	115	-	140
●	R302180.T45D16	180	45	230	48	95	16	150	-	180
●	R302200.T50D16	200	50	240	48	95	16	150	3297	200



Arbel Agencies LTD.  
11 Ba'alei Hamelacha st. Qiryat Bialik P.O.B 1095, ZIP 2751311, ISRAEL  
+972(0)48736969 ☎ +972(0)48730708 📠 info@arbel-ltd.com 📧 www.arbel-ltd.com 🌐

