

# R259



## POLYAMIDE / POLYURETHANE WHEEL WITH RIGID STEEL FORK AND STEEL BEARINGS (HEAVY DUTY SERIES)

### Materials:

#### Wheel body (1):

Polyamide. Resistant to oils and greases.

#### Tread (2):

Injected polyurethane. Hardness  $60 \pm 5$  Shore D.

#### Surface finish:

Smooth.

#### Colour:

(1) Natural white.

(2) Red (Ral 3013).

(3-4-5-6) Galvanised blue.

#### Wheel rotation (4):

A pair of steel ball bearings is inserted in the wheel hub to provide excellent rollability.

#### Bracket (3):

Extra-thick steel (DD13) fork, with mounting holes in the base.

#### Wheel fastening (6):

Steel hex head screw, coupled with a self-locking steel nut.

#### Special requests:

- Upon request and for a minimum of 20 pieces, the wheel can be supplied with a needle roller cage, (replace code no. R259 with code no. R249).

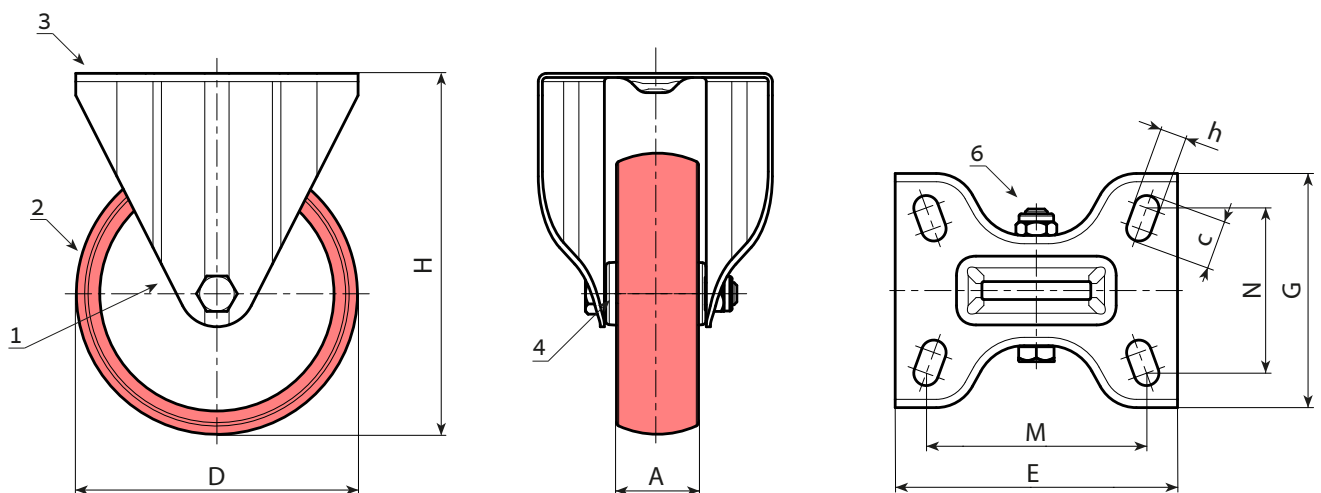

Stock availability as % (🛒)  
90% (●) - 40% (●) - 5% (●)

🛒	art.	D	A	H	E	G	M	N	c	h	g	F1 (Kg)
●	R259080.T34P080X060	80	34	125	100	88	80	60	12	9	-	260
●	R259100.T40P080X060	100	40	135	100	88	80	60	12	9	-	300
●	R259125.T40P080X060	125	40	161	100	88	80	60	12	9	-	400
●	R259150.T45P105X080	150	45	195	134	114	105	80	23	12	-	600
●	R259200.T50P105X080	200	50	242	134	114	105	80	23	12	-	700



11 Ba'alei Hamelacha st. Qiryat Bialik P.O.B 1095, ZIP 2751311, ISRAEL  
+972(0)48736969 ☎ +972(0)48730708 📠 info@arbel-ltd.com 📧 www.arbel-ltd.com 🌐

