

R200



WHEEL WITH POLYAMIDE BODY AND INJECTED POLYURETHANE TREAD (WITHOUT RIG)

Materials:

Wheel body:

Polyamide. Resistant to oils and greases.

Tread:

Injected polyurethane. Hardness 60 ± 5 Shore D.

Surface finish:

Smooth.

Colour:

Body:

Natural white.

Tread:

Red (Ral 3013).

Wheel rotation:

The hole for the pivot pin is formed by plastic moulding.

Special requests:

- Upon request and for a minimum of 20 pieces, the wheel can be supplied with a needle roller cage, (replace code no. R200 with code no. R230).

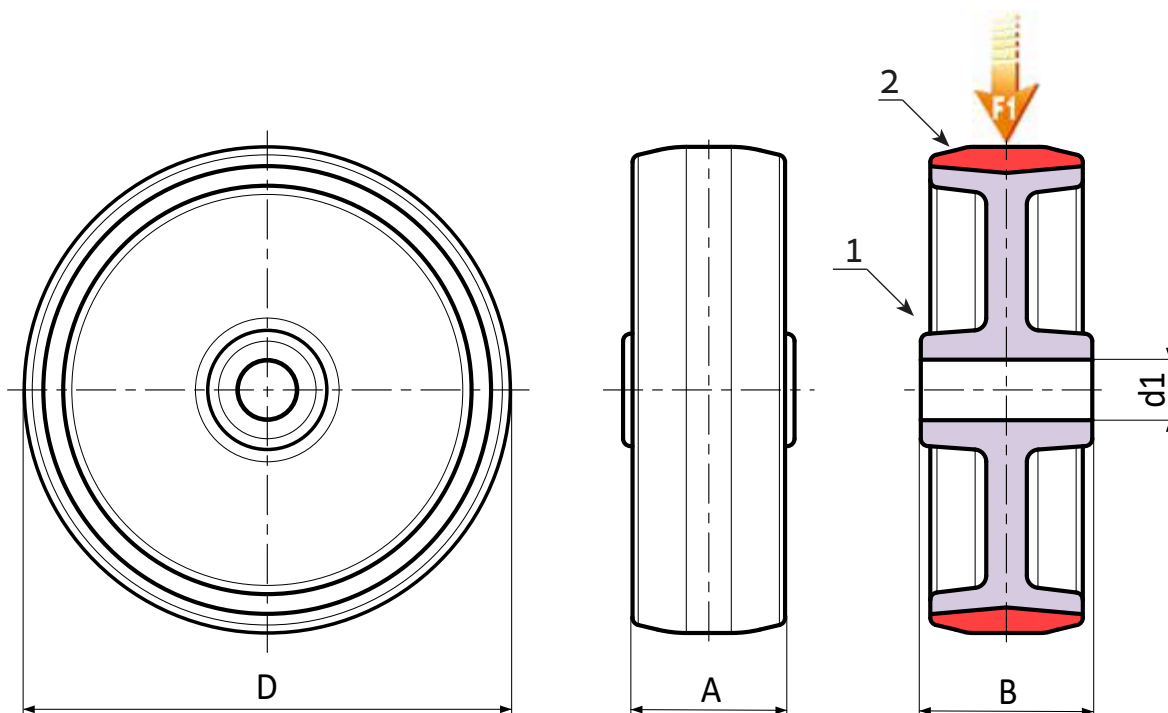

Stock availability as % (🛒)
90% (●) - 40% (●) - 5% (●)

🛒	art.	D	A	B	d1	g	F1 (Kg)
●	R200080.T30D12	80	30	40	12	104	100
●	R200100.T30D12	100	30	40	12	152	130
●	R200125.T35D15	125	35	44	15	254	200
●	R200150.T40D15	150	40	44	15	229	250
●	R200200.T50D20	200	50	58	20	818	365