

R109CIN

INOX

max
4 Km/h

+80°
-25°

PA6

UL94
HB

RoHS
COMPLIANT

POLYAMIDE MONOLITHIC WHEEL WITH RIGID STAINLESS STEEL FORK

Materials:

Wheel body (1):

Polyamide. Resistant to oils and greases.

Tread (2):

Polyamide. Resistant to oils and greases.

Surface finish:

Smooth.

Colour:

(1-2) Natural white.

(3-4-6) Natural stainless steel.

Wheel rotation (4):

The hole for the pivot pin is formed by plastic moulding. A stainless steel (Aisi 304) tube is positioned between the stud and the hole for protection.

Bracket (3):

Rigid stainless steel (Aisi 304) fork, with mounting holes in the base.

Wheel fastening (6):

Stainless steel (Aisi 304) hex head bolt, coupled with a stainless steel (Aisi 304) nut.

Special requests:

- Upon request and for a minimum of 20 pieces, the wheel can be supplied with a needle roller cage, (replace code no. R109CIN with code no. R139CIN).

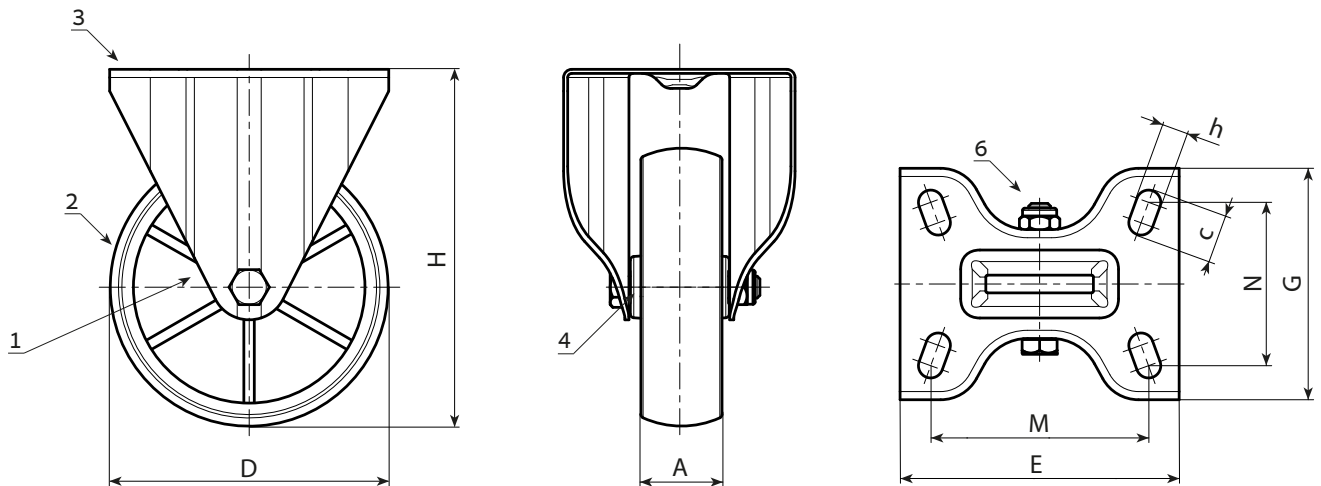

BOTECO
COMPONENTS

Stock availability as % (🛒)
90% (●) - 40% (●) - 5% (●)

🛒	art.	D	A	H	E	G	M	N	c	h	9	F1 (Kg)
●	R109080.T30P080X060CIN	80	30	108	100	84	80	60	12	9	312	100
●	R109100.T30P080X060CIN	100	30	127	100	84	80	60	12	9	347	130
●	R109125.T39P080X060CIN	125	39	155	100	84	80	60	12	9	532	180
●	R109150.T40P080X060CIN	150	40	184	100	84	80	60	12	9	-	140
●	R109175.T45P105X080CIN	175	45	228	135	110	105	80	23	11	-	300
●	R109200.T50P105X080CIN	200	50	240	135	110	105	80	23	11	1444	300

Arbel Agencies LTD.

arbel
AGENCIES LIMITED

11 Ba'alei Hamelacha st. Qiryat Bialik P.O.B 1095, ZIP 2751311, ISRAEL
+972(0)48736969 ☎ +972(0)48730708 📠 info@arbel-ltd.com 📧 www.arbel-ltd.com 🌐

BOTECO