

# P912



## MOUNTING FOOT WITH GROUND FIXING AND STEEL ARTICULATED STEM TYPE B - BALL R12.4

### Materials:

Reinforced polyamide. Resistant to oils and greases.

### Surface finish:

Satin.

### Colour:

Black (RAL 9011).

### Inserts:

#### P912:

Galvanised steel threaded and articulated stem (ball R.12.4) with milled seat for wrench (type B) (thread tolerance 6g).

#### P912CIN:

Stainless steel threaded and articulated stem (ball R.12.4) with milled seat for wrench (type B) (Aisi 303) (thread tolerance 6g).

### Ground fixing:

The mounting foot is supplied with closed holes for anchoring to the ground. To open them pierce the plastic membrane (see drawing).

### Special requests:

- Upon request and for special quantities inserts can be supplied with customised lengths.
- Upon request and for special quantities the foot can be supplied in Orange (RAL 2004).

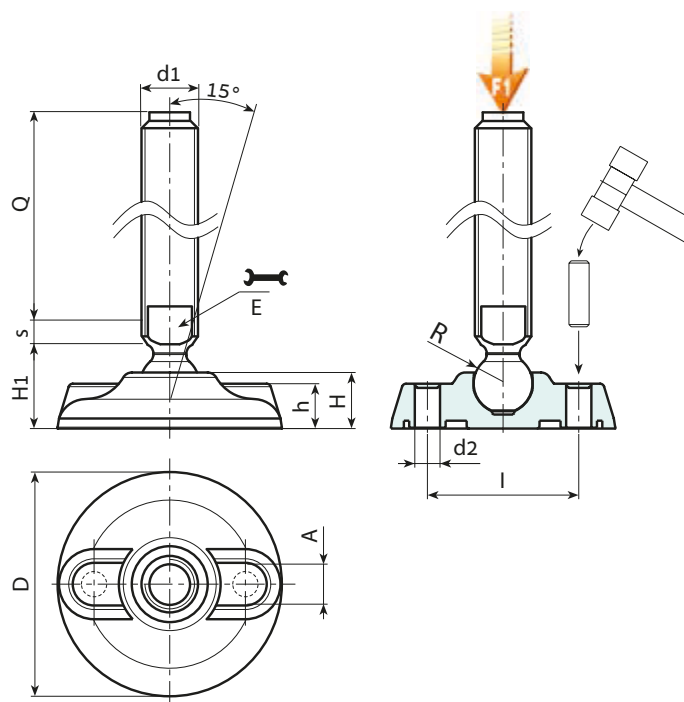

### Version P912: Mounting foot with stem type B (with milled seat for wrench) and ball R12.4

Stock availability as % (🛒)  
90% (●) - 40% (●) - 5% (●)

Art.	D	H	I	H1	h	A	E	s	d2	R	d1 <sub>6g</sub>	Q	g	F1 (kN)
P912080.TM16X..01	80	20	54	25.5	16	20	13	7	9	12.5	M16	70-90-110-130-150-170	146-172-198-224-250-276	10

### Version P912CIN: Mounting foot with stem type B - stainless steel - (with milled seat for wrench) and ball R12.4



Art.	D	H	I	H1	h	A	E	s	d2	R	d1 <sub>6g</sub>	Q	g	F1 (kN)
P912080.TM16X..01CIN	80	20	54	25.5	16	20	13	7	9	12.5	M16	110-130-150-170	198-224-250-276	10

Enter the selected stud length in place of the two dots . . in the item code. Customised stud length available for a minimum of 100 pieces.  
Attention: The expressed load limit F1 is lower than the break load by 30% and is intended as static.