

P911



MOUNTING FOOT WITH GROUND FIXING AND STEEL ARTICULATED STEM TYPE A - BALL R12.4

Materials:

Reinforced polyamide. Resistant to oils and greases.

Surface finish:

Satin.

Colour:

Black (RAL 9011).

Inserts:

P911:
Galvanised steel threaded and articulated stem (ball R.12.4) with hexagonal base (thread tolerance 6g).

P911CIN:
Stainless steel threaded and articulated stem (ball R.12.4) with hexagonal base (Aisi 303) (thread tolerance 6g).

Ground fixing:

The mounting foot is supplied with closed holes for anchoring to the ground. To open them pierce the plastic membrane (see drawing).

Special requests:

- Upon request and for special quantities inserts can be supplied with customised lengths.
- Upon request and for special quantities the foot can be supplied in Orange (RAL 2004).

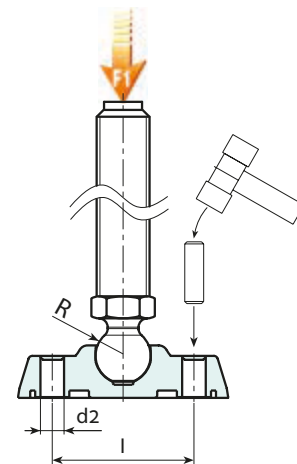
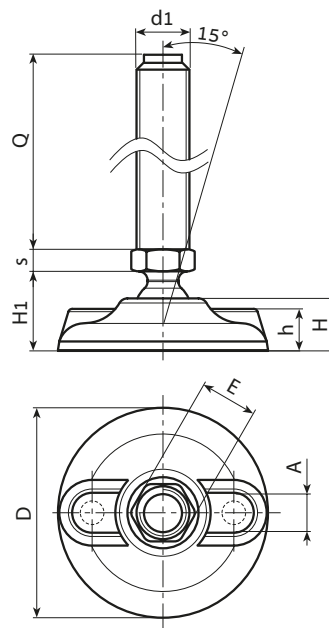

Version P911: Mounting foot with stem type A (with hexagonal base) and ball R12.4

Stock availability as % (🛒)
90% (●) -40% (●) -5% (●)

Art.	D	H	I	H1	h	A	E	s	d2	R	d1 _{6g}	Q	g	F1 (kN)
P911080.TM08X..01	80	20	54	25.5	16	20	13	5	9	12.5	M8	45-70	66-73	10
P911080.TM10X..01	80	20	54	25.5	16	20	13	5	9	12.5	M10	45-70-100	74-86-123	10
P911080.TM12X..01	80	20	54	25.5	16	20	13	5	9	12.5	M12	45-70-100	84-101-145	10

Version P911CIN: Mounting foot with stem type A (with hexagonal base) and ball R12.4 - stainless steel

INOX

Art.	D	H	I	H1	h	A	E	s	d2	R	d1 _{6g}	Q	g	F1 (kN)
P911080.TM08X..01CIN	80	20	54	25.5	16	20	13	5	9	12.5	M8	45-70	66-73	10
P911080.TM10X..01CIN	80	20	54	25.5	16	20	13	5	9	12.5	M10	45-70	74-86	10
P911080.TM12X..01CIN	80	20	54	25.5	16	20	13	5	9	12.5	M12	45-70-100	84-101-145	10

Enter the selected stud length in place of the two dots . . in the item code. Customised stud length available for a minimum of 100 pieces.

Attention: The expressed load limit F1 is lower than the break load by 30% and is intended as static.

Arbel Agencies LTD.



11 Ba'alei Hamelacha st. Qiryat Bialik P.O.B 1095, ZIP 2751311, ISRAEL
+972(0)48736969 ☎ +972(0)48730708 📠 info@arbel-ltd.com 📧 www.arbel-ltd.com 🌐

