

P530



FULL STEEL MOUNTING FOOT WITH ARTICULATED STEM TYPE A - BALL R12.5

Materials:

P530:

Turned free-cutting steel mounting foot base.

P530CIN:

Turned stainless steel mounting foot base (Aisi 303).

Surface finish:

Smooth.

Colour:

P530:

Standard blue galvanising.

P530CIN:

Natural.

Inserts:

P530:

Galvanised steel threaded and articulated stem (ball R.12.5) with hexagonal base (thread tolerance 6g).

P530CIN:

Stainless steel threaded and articulated stem (ball R.12.5) with hexagonal base (Aisi 303) (thread tolerance 6g).

Stem fixing method:

The stem cannot be disassembled. The ball cannot be removed as the edge of its seat has been pressed in.

Special requests:

- Upon request and for special quantities inserts can be supplied with customised lengths.

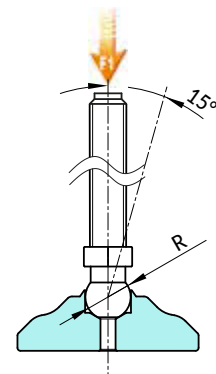
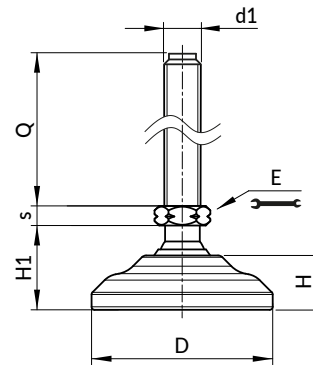

Version P530: Galvanised steel mounting foot with stem type A (with hexagonal base) and ball R12.5

Stock availability as % (🛒)
90% (●) - 40% (●) - 5% (●)

Art.	D	H	H1	E	s	R	d1 _{6g}	Q	g	F1 (kN)
P53040.VZM08X..	40	11,5	20	13	5	15	M8	45-70	132-139	50
P53040.VZM10X..	40	11,5	20	13	5	12.5	M10	45-70-100	140-152-179	23
P53040.VZM12X..	40	11,5	20	13	5	12.5	M12	45-70-100	149-168-188	23
P53060.VZM08X..	60	18	28	13	5	12.5	M8	45-70	295-302	13
P53050.VZM10X..	50	13.5	23	13	5	12.5	M10	45-70-100	203-215-240	23
P53050.VZM12X..	50	13.5	23	13	5	12.5	M12	45-70-100	212-231-251	23
P53060.VZM08X..	60	18	28	13	5	12.5	M8	45-70	295-302	13
P53060.VZM10X..	60	18	28	13	5	12.5	M10	45-70-100	303-315-340	23
P53060.VZM12X..	60	18	28	13	5	12.5	M12	45-70-100	312-331-351	23

Version P530CIN: Stainless steel mounting foot with stem type A (with hexagonal base) and ball R12.5



Art.	D	H	H1	E	s	R	d1 _{6g}	Q	g	F1 (kN)
P53040.INM08X..CIN	40	11,5	20	13	5	12.5	M8	45-70	132-139	13
P53040.INM10X..CIN	40	11,5	20	13	5	12.5	M10	45-70-100	140-152-179	23
P53040.INM12X..CIN	40	11,5	20	13	5	12.5	M12	45-70-100	149-168-188	23
P53050.INM08X..CIN	50	13.5	23	13	5	12.5	M8	45-70	195-202	13
P53050.INM10X..CIN	50	13.5	23	13	5	12.5	M10	45-70-100	203-215-240	23
P53050.INM12X..CIN	50	13.5	23	13	5	12.5	M12	45-70-100	212-231-251	23
P53060.INM08X..CIN	60	18	28	13	5	12.5	M8	45-70	295-302	13
P53060.INM10X..CIN	60	18	28	13	5	12.5	M10	45-70-100	303-315-340	23
P53060.INM12X..CIN	60	18	28	13	5	12.5	M12	45-70-100	312-331-351	23

Enter the selected stud length in place of the two dots . . in the item code. Customised stud length available for a minimum of 100 pieces.

Attention: The expressed load limit F1 is lower than the break load by 30% and is intended as static.



Arbel Agencies LTD.

11 Ba'alei Hamelacha st. Qiryat Bialik P.O.B 1095, ZIP 2751311, ISRAEL

+972(0)48736969 ☎ +972(0)48730708 📠 info@arbel-ltd.com 📧 www.arbel-ltd.com 🌐

