

P300



CYLINDRICAL ANTI-VIBRATION MOUNT WITH DOUBLE THREADED STUD

Materials:

Natural rubber (NR),

Rubber hardness:

Hardness 55 Shore A (tolerance $\pm 5\%$).

Surface finish:

Smooth.

Colour:

Black (RAL 9011).

Inserts:

- (1) Galvanised boron steel threaded stud (thread tolerance 6g).
- (2) Galvanised weldable steel washer.

Special requests:

- Upon request and for a minimum quantity of 100 pieces anti-vibration mounts can be supplied with hardness 45 or 70 Shore A.
- Upon request and for a minimum quantity of 100 pieces anti-vibration mounts can be supplied in different materials.
- P301 = SBR
- P302 = NBR
- P303 = EPDM

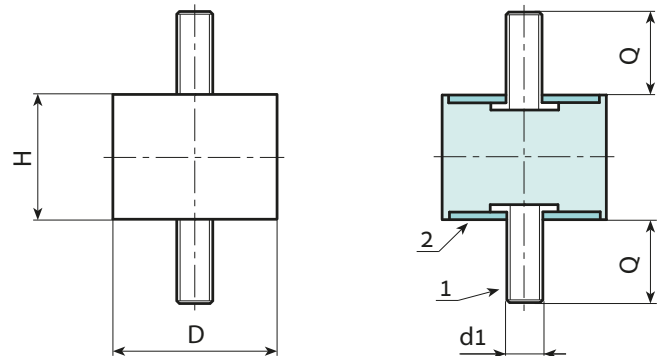

Stock availability as % (🛒)
90% (●) - 40% (●) - 5% (●)

🛒	Art.	D	H	d1 _{6g}	Q	📦	Compression stiffness (N/mm)
●	P300008.F08M03X1055	8	8	M3	10	1.5	37.9
●	P300015.F10M04X1055	15	10	M4	10	5.5	141.7
●	P300015.F15M04X1055	15	15	M4	10	6.5	56.5
●	P300015.F20M04X1055	15	20	M4	10	6.5	44.6
●	P300020.F15M06X1555	20	15	M6	16	18	122.8
●	P300020.F20M06X1555	20	20	M6	16	19	94
●	P300020.F25M06X1555	20	25	M6	16	20	35.9
●	P300025.F15M06X1855	25	15	M6	18	17	211.5
●	P300025.F20M06X1855	25	20	M6	18	27	130.5
●	P300025.F25M06X1855	25	25	M6	18	28	89.8
●	P300025.F30M08X1855	25	30	M8	18	33	67.2
●	P300030.F15M08X2055	30	15	M8	20	44	456.8
●	P300030.F20M08X2055	30	20	M8	20	48	190.8
●	P300030.F30M08X2055	30	30	M8	20	59	100.3
●	P300040.F20M08X2355	40	20	M8	23	54	295.2
●	P300040.F30M08X2355	40	30	M8	23	92	196
●	P300040.F40M10X2855	40	40	M10	28	116	125.6
●	P300050.F20M10X2855	50	20	M10	28	125	930
●	P300050.F30M10X2855	50	30	M10	28	151	369.2
●	P300050.F40M10X2855	50	40	M10	28	171	242.7
●	P300050.F45M10X2855	50	45	M10	28	182	178.6
●	P300050.F50M10X2855	50	50	M10	28	187	160.9
●	P300060.F30M10X2855	60	30	M10	28	214	585.6
●	P300060.F40M10X2855	60	40	M10	28	244	346.9
●	P300070.F40M10X2855	70	40	M10	28	325	504.8
●	P300075.F30M12X3755	75	30	M12	37	354	961.6
●	P300075.F55M14X3755	75	55	M14	37	465	408.3
●	P300100.F40M16X4255	100	40	M16	42	816	1817.2
●	P300100F.55M16X4255	100	55	M16	42	934	878.9
●	P300100F.75M16X4255	100	75	M16	42	1113	530.1

Arbel Agencies LTD.



11 Ba'alei Hamelacha st. Qiryat Bialik P.O.B 1095, ZIP 2751311, ISRAEL
+972(0)48736969 ☎ +972(0)48730708 📠 info@arbel-ltd.com 📧 www.arbel-ltd.com 🌐

