

# N282



## KNURLED INDEXING KNOB WITH STEPLESS POSITIONING AND LOCKING ACTION

### Materials:

1. Hardened steel C45 base with fixing holes.
2. Aluminium (alloy 2011) flange with laser engraved numbers.
3. Reinforced polyamide control knob. Resistant to oils and greases.
4. Stainless steel fastening cap with hexagon socket (Aisi 303).
5. PA6 cap.
6. Fastening snap ring in stainless steel (UNI 653).
7. High resistance tempered and hardened steel rotating cam shaft, with through hole and key.
8. Stainless steel knob insert (Aisi 303).
10. Stainless steel (Aisi 303) self-tapping screws TCS 2.9x19 for fastening the bush.
11. Aluminium (alloy 2011) turned unlocking pin holder bush.
12. Stainless steel (Aisi 302) pressure spring.
13. Hardened stainless steel locking roller (Aisi 52100 grade G2).
14. 2 turned stainless steel unlocking pins (Aisi 303).
15. Steel fixing screw M03x8 DIN 5933 for aluminium flange.

### Surface finish:

- 1-2-4-7-8. Glossy.
- 3-5. Satin.

### Colour:

1. Black-oxide treated.
2. Anodized black.
3. Black (RAL 9011).
- 4-7. Natural.

### Fastening to the machine:

Fixed to the machine with 3 x M05 hex socket head cap screws (number 9 in the drawing) (DIN 912).

### Hole:

The shaft hole is machined to H7 tolerance. Side fixing hole is not required. The diameter of the hole is fixed and cannot be varied.

### Coupling of the shaft to the knob:

The shaft is coupled to the knob by means of a shaft with keyway. Attention! The key, for technical reasons, is small in size. See attached diagram for bore/shaft dimensions.

### Graduated flange:

The flange is available in two versions:

#### V1

The standard numbering of the flange goes from 0 to 9 with 10 graduations for each unit. (100 graduations).

#### V2

Vertical line without numbers.

#### Attention!

Select the rotation direction (O= clockwise A=counter clockwise).

### Special requests:

- Central cap available upon request in the colours indicated in the chart on [page].
- The flange with customised numbering is available upon request and for special quantities (50 pieces).

### Limitations:

The knob is not capable of supporting the weight of the shaft to which it is coupled; consequently it does not replace the normal support systems (bearings, flanges, etc.).

The knob cannot be installed if there is a motor drive present.

Lowered key in compliance with DIN 6885-2

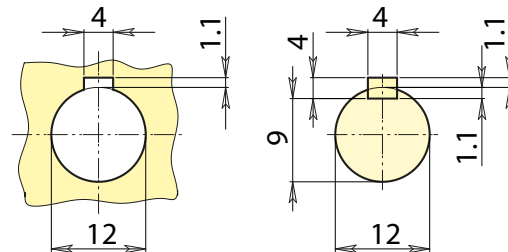

Stock availability as % (🛒)  
90% (●) - 40% (●) - 5% (●)

# N282

## KNURLED INDEXING KNOB WITH STEPLESS POSITIONING AND LOCKING ACTION

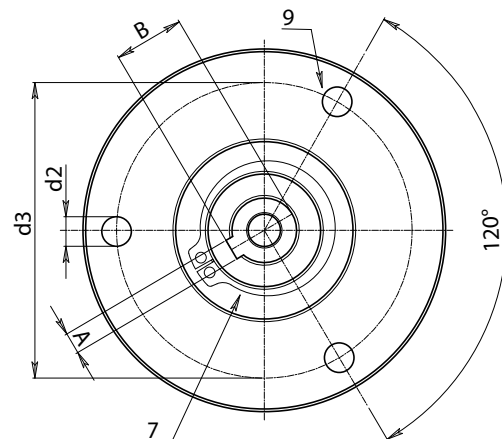
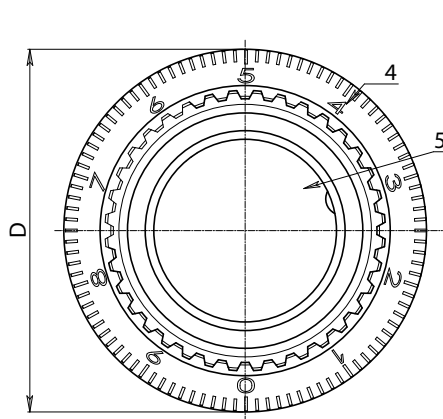
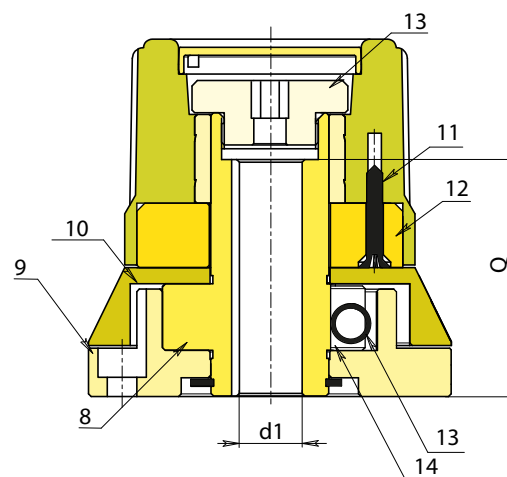
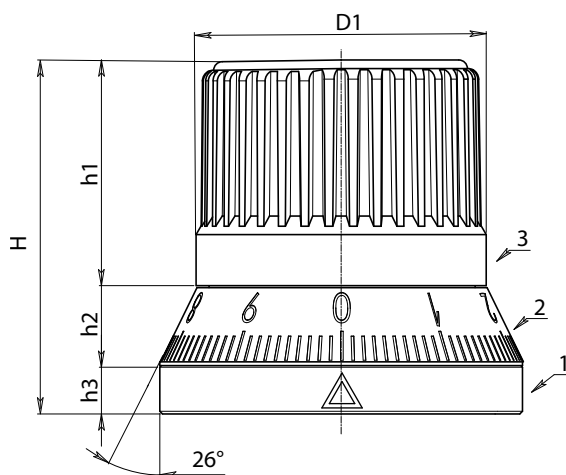

Stock availability as % (🛒)  
 90% (●) - 40% (●) - 5% (●)

🛒	Art.	D	H	D1	h1	h2	h3	d3	d2	A	B	d1H7	Q	🛒
●	N28254.SBZ200101V1	67,5	66	54	42	15	9	55	5,5	4	13,1	12	44	625