

M137

HANDLE WITH LEVER ARM



Materials:

Reinforced polyamide. Resistant to oils and greases.

Surface finish:

Satin.

Colour:

Black (RAL 9011).

Insert:

Galvanised steel partially threaded stud (thread tolerance 6g).

Fixing method:

Push fit after moulding (high temperature), not removable.

Special Requests:

- Upon request and for special quantities inserts can be supplied with dimensions according to customer's drawing.
- Upon request and for special quantities inserts can be supplied in different materials/with different coatings.
- Upon request and for special quantities available in the colours indicated in the chart [page].

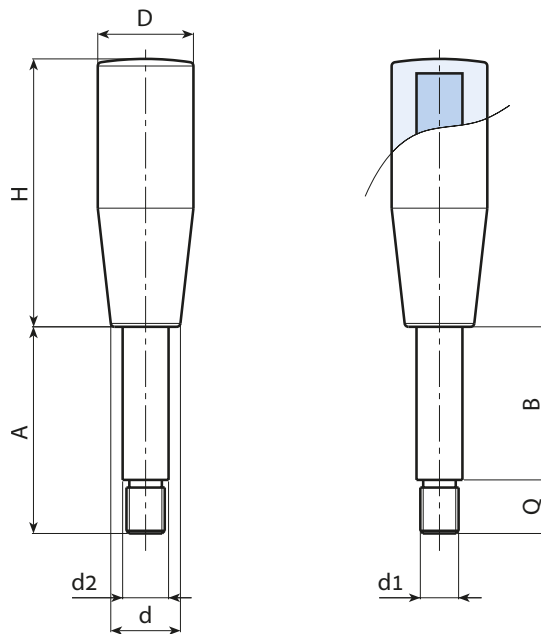

Stock availability as % (🛒)
90% (●) - 40% (●) - 5% (●)

🛒	art.	H	D	d	B	d2	A	d1 _{6g}	Q	📦
●	M13750.TI10X2501	50,5	20	15	15	10	25	M8	10	50
●	M13750.TI10X3001	50,5	20	15	21	10	30	M8	10	50
●	M13750.TI10X4001	50,5	20	15	30	10	40	M8	10	55
●	M13750.TI10X5501Z1	50,5	20	15	45	10	55	M8	10	66
●	M13750.TI10X8001	50,5	20	15	70	10	80	M8	10	82
●	M13760.TI12X5801	61	23,5	18	44	12	58	M10	14	114
●	M13760.TI12X6501	61	23,5	18	50	12	65	M10	15	114
●	M13760.TI12X9501	61	23,5	18	80	12	95	M10	15	132
●	M13770.TI14X6501	70	25,5	18,5	50	14	65	M12	15	142
●	M13770.TI14X10501	70	25,5	18,5	90	14	105	M12	15	190
●	M13780.TI14X6501	79,5	26	22	50	14	65	M12	15	160
●	M13780.TI14X10501	79,5	26	22	90	14	105	M12	15	209
●	M13790.TI16X6701	89,5	28	23,5	50	16	67	M14	17	150
●	M13790.TI16X9701	89,5	28	23,5	80	16	97	M14	17	272
●	M13790.TI16X11701	89,5	28	23,5	100	16	117	M14	17	305

Arbel Agencies LTD.



11 Ba'alei Hamelacha st. Qiryat Bialik P.O.B 1095, ZIP 2751311, ISRAEL
+972(0)48736969 ☎ +972(0)48730708 📠 info@arbel-ltd.com 📧 www.arbel-ltd.com 🌐

