

# L804

## "EUROMODEL" WING NUT WITH THREADED STUD



MODELLO DEPOSITATO

### Materials:

Reinforced polyamide.  
Resistant to oils and greases.

### Surface finish:

Satin.

### Colour:

Black (RAL 9011).

### Central Cap:

Grey PA6 (RAL 7035 code 13).

### Alternative Cap colours:

Orange (RAL 2004 code 02).  
Blue (RAL 5015 code 07).  
Yellow (RAL 1021 code 10).  
Red (RAL 3000 code 16).  
Green (RAL 6024 code 17).  
Black (RAL 9011 code 01).

### Inserts:

#### L804:

Galvanised steel threaded stud (thread tolerance 6g).

#### L804CIN:

Stainless steel threaded stud (Aisi 303) (thread tolerance 6g).

### Special requests:

- Upon request and for special quantities inserts can be supplied with customised lengths.
- Upon request and for special quantities inserts can be supplied in different materials.
- Upon request and for special quantities available in the colours indicated in the chart (attention: reduced range) [page].

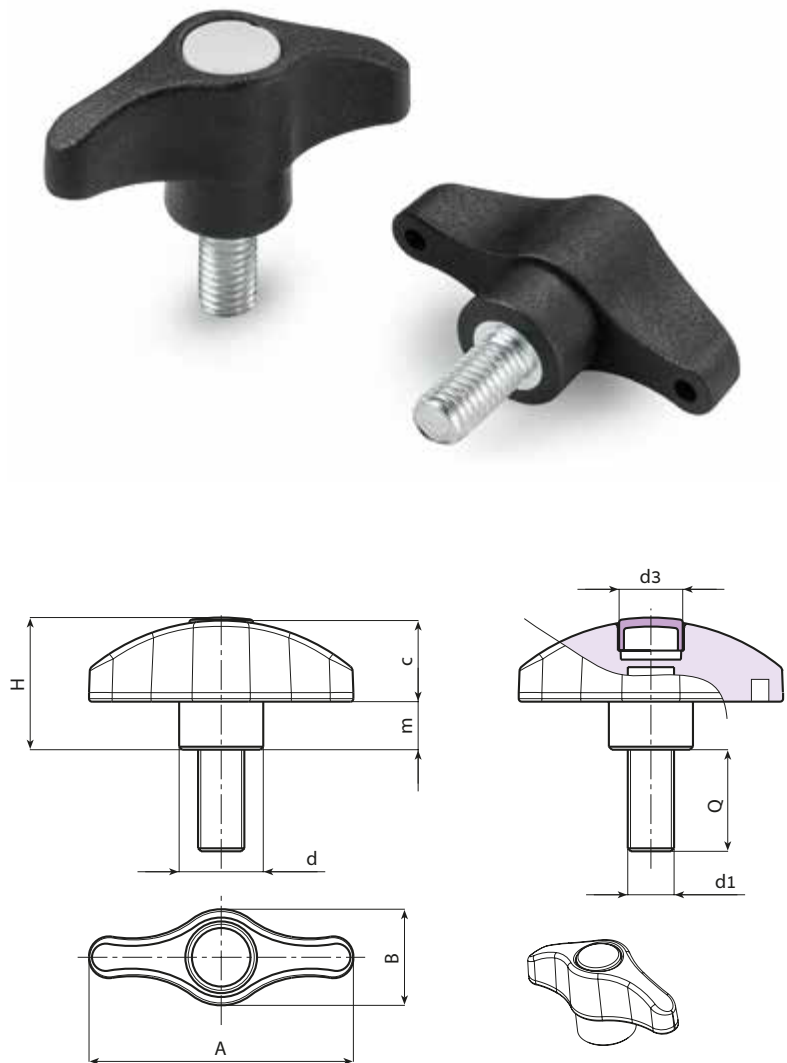

Stock availability as % (🛒)  
90% (●) - 40% (●) - 5% (●)

### Version L804 - galvanised steel stud.

art.	A	B	H	m	c	d	d3	LM	d1 <sub>6g</sub>	Q	📦
L80444.TM05X..0113	44	16	22	8	14	14	10	80	M5	16-20-25-30-40-50	11-11,5-12-12,5-13,5-14,5
L80444.TM06X..0113	44	16	22	8	14	14	10	80	M6	16-20-25-30-40-50	12-13-14-15-16-17
L80444.TM08X..0113	44	16	22	8	14	14	10	80	M8	16-20-25-30-40-50	19-20,5-22-23,5-26-29
L80452.TM06X..0113	52	19	26	9,5	16,5	17	13	80	M6	16-20-25-30-40-50	17-18-19-20-21-22
L80452.TM08X..0113	52	19	26	9,5	16,5	17	13	80	M8	16-20-25-30-40-50	24-25,5-27-28,5-31-34
L80452.TM10X..0113	52	19	26	9,5	16,5	17	13	80	M10	20-25-30-40-50	32-35-38-42-47
L80467.TM06X..0113	67	24	32,5	11	21,5	21	16	100	M6	A.R.	-
L80467.TM08X..0113	67	24	32,5	11	21,5	21	16	100	M8	16-20-25-30-40-50	32-33,5-35-36,5-39,5-42,5
L80467.TM10X..0113	67	24	32,5	11	21,5	21	16	100	M10	30-50	44,5-54,5
L80467.TM12X..0113	67	24	32,5	11	21,5	21	16	100	M12	30-40	52-59

Enter the selected stud length in place of the two dots .. in the item code.

A.R. = Customised stud length available for a minimum of 250 pieces.

LM = Maximum mouldable length.

INOX

### Version L804CIN: stainless steel stud (Aisi 303).

art.	A	B	H	m	c	d	d3	LM	d1 <sub>6g</sub>	Q	📦
L80444.TM06X..0113CIN	44	16	22	8	14	14	10	80	M6	A.R.	-
L80452.TM08X..0113CIN	52	19	26	9,5	16,5	17	13	80	M8	A.R.	-
L80467.TM10X..0113CIN	67	24	32,5	11	21,5	21	16	100	M10	A.R.	-

Enter the selected stud length in place of the two dots .. in the item code.

A.R. = Customised stud length available for a minimum of 250 pieces.

LM = Maximum mouldable length.

Arbel Agencies LTD.



11 Ba'alei Hamelacha st. Qiryat Bialik P.O.B 1095, ZIP 2751311, ISRAEL  
+972(0)48736969 ☎ +972(0)48730708 📠 info@arbel-ltd.com 📧 www.arbel-ltd.com 🌐

