

K902



SOLID CONTROL HANDWHEEL WITH INDICATOR SEAT AND REVOLVING HANDLE

Materials:

Reinforced and stabilized polyamide. Resistant to oils and greases.

Surface finish:

Satin.

Colour:

Black (RAL 9011).

Main insert:

Galvanised steel insert with smooth through bore (tolerance H10).

Lateral insert:

Brass insert with threaded through hole.

Lateral handle:

K902: Revolving handle art. M144 page (400).

K906: Revolving handle art. M129 page (401).

K907: Revolving handle art. M145 page (404).

K908: Revolving handle art. M202 page (408).

Mountable indicator:

Use gravity position indicators models K650 or K660. The indicator can be only used in a vertical position (horizontal machine axis). The indicator and the corresponding grub screw d7 must be purchased separately. For further information on the indicators see the pages of articles K650 and K660 [page 362 363 and page 364 365].

(*) With adapter KS08050.T01 you can mount the indicator K650050.

Fixing method:

For fixing systems, or execution of keyways or square holes, please refer to the technical notes attached to the catalogue [page 814].

Special requests:

- Upon request and for a minimum of 50 pieces inserts can be supplied with hole d1 with tolerance H7 and black oxide treated finish. Add letters ZB to the standard code. Example: K902100.T050D1001PZB.
- Upon request and for special quantities inserts can be supplied with custom hole diameter d1.
- Upon request and for special quantities inserts can be supplied in different materials/with different coatings.
- The indicator must be ordered separately.
- Upon request and for special quantities it is possible to change the indicator seat.

Combinations Diameters/Indicators:

d5=52.4 --> K650050

d5=87.4 --> K650080 or K660080

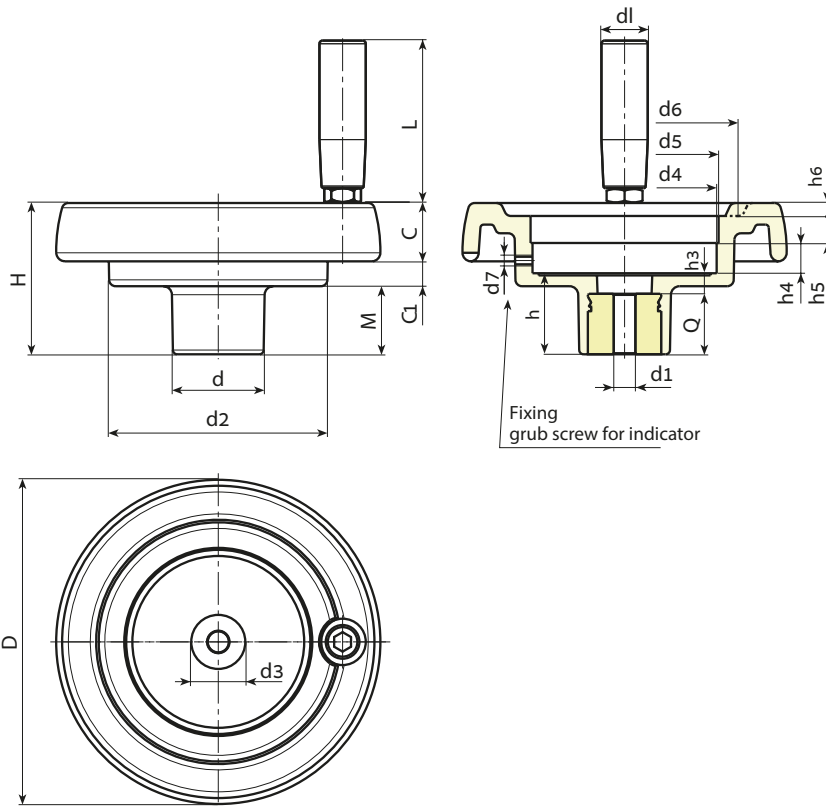

Stock availability as % (🛒)
90% (●) - 40% (●) - 5% (●)

art.	D	H	d	d2	M	C	C1	d3	d4	d5	d6	d7	h	h3	h4	h5	h6	dl	L	Dm	d1H10	Q	g
K902087.T050P5,801P	86	53	32	62	21	17	15	20	50.8	52.4	63	M6	26.5	6.5	11.5	12	3	20	56	12	5.8	20	185
K902100.T050P6,801P	99	55.5	32	63	23.5	20.5	11.5	20	50.8	52.4	68	M6	29	9	11.5	12	3.5	20	56	12	6.8	20	200
K902130.T080P6,801P	129	64.5	42	100	27.5	23	14	29	85.7	87.4*	90	M6	34	10	13.5	12.5	5	21	65	20	6.8	24	406
K902150.T080P6,801P	149	69	42	101	31	25.5	12.5	29	85.7	87.4*	106	M6	37	9	13.5	12.5	6.5	23	76	20	6.8	28	530
K902175.T080P6,801P	175	72	40	115	28.5	32	11.5	25	85.7	87.4*	126.5	M6	38	10	12.5	14	8	25	86	20	6.8	28	760
K902200.T080P6,801P	199	71	46	137	24	32	15	29	123	87.4	144	M6	34	11	13.5	12.5	10	25	86	22	6.8	23	920

Attention: For a minimum of 50 pieces the diameter d1 can be customised (hole tolerance H10 galvanised and H7 black-oxide treated).
Dm = Maximum obtainable diameter for subsequent machining (widening).



11 Ba'alei Hamelacha st. Qiryat Bialik P.O.B 1095, ZIP 2751311, ISRAEL
+972(0)48736969 ☎ +972(0)48730708 📠 info@arbel-ltd.com 📧 www.arbel-ltd.com 🌐



K906



SOLID CONTROL HANDWHEEL WITH INDICATOR SEAT AND REVOLVING HANDLE M129

art.	D	d5	d7	d1	L	Dm	d1H10	Q	
K906087.T050P6,801P	86	52.4	M6	20	52	12	5.8	20	197
K906100.T050P6,801P	99	52.4	M6	20	52	12	6.8	20	212
K906130.T080P6,801P	129	87,4*	M6	23	62	20	6.8	24	410
K906150.T080P6,801P	149	87,4*	M6	25	72	20	6.8	28	522
K906175.T080P6,801P	175	87,4*	M6	25	81	20	6.8	28	750
K906200.T080P6,801P	199	87,4	M6	25	81	22	6.8	23	910

Attention: For a minimum of 50 pieces the diameter d1 can be customised (hole tolerance H10 galvanised and H7 black-oxide treated).
Dm = Maximum obtainable diameter for subsequent machining (widening).

Insert:

Galvanised steel insert with smooth through bore (tolerance H10).

Lateral handle:

Revolving handle art. M129 [page 401].

K907



SOLID CONTROL HANDWHEEL WITH INDICATOR SEAT AND REVOLVING HANDLE M145

art.	D	d5	d7	d1	L	Dm	d1H10	Q	
K907087.T050P5,801P	86	52.4	M6	20	55	12	5.8	20	187
K907100.T050P6,801P	99	52.4	M6	20	55	12	6.8	20	205
K907130.T080P6,801P	129	87,4*	M6	23	66	20	6.8	24	424
K907150.T080P6,801P	149	87,4*	M6	25	76	20	6.8	28	516
K907175.T080P6,801P	175	87,4*	M6	25	87	20	6.8	28	745
K907200.T080P6,801P	199	87,4	M6	27	87	22	6.8	23	900

Attention: For a minimum of 50 pieces the diameter d1 can be customised (hole tolerance H10 galvanised and H7 black-oxide treated).
Dm = Maximum obtainable diameter for subsequent machining (widening).

Insert:

Galvanised steel insert with smooth through bore (tolerance H10).

Lateral handle:

Revolving handle art. M145 [page 404].

K908



SOLID CONTROL HANDWHEEL WITH INDICATOR SEAT AND REVOLVING HANDLE M202

art.	D	d5	d7	d1	L	Dm	d1H10	Q	
K908150.T080P6,801P	149	87,4*	M6	40	64	20	6.8	28	525
K908175.T080P6,801P	175	87,4*	M6	40	64	20	6.8	28	745
K908200.T080P6,801P	199	87,4	M6	40	64	22	6.8	23	905

Attention: For a minimum of 50 pieces the diameter d1 can be customised (hole tolerance H10 galvanised and H7 black-oxide treated).
Dm = Maximum obtainable diameter for subsequent machining (widening).

Insert:

Galvanised steel insert with smooth through bore (tolerance H10).

Lateral handle:

Revolving handle art. M202 [page 408].

Stock availability as %
90% - 40% - 5%