

K903



SOLID CONTROL HANDWHEEL WITH INDICATOR SEAT, REVOLVING HANDLE AND LOCKING KNOB

Materials:

Reinforced and stabilized polyamide.
Resistant to oils and greases.

Surface finish:

Satin.

Colour:

Black (RAL 9011).

Insert:

Galvanised steel insert with smooth through bore (tolerance H10).

Mountable indicator:

Use gravity position indicators models K650 or K660. The indicator can be only used in a vertical position (horizontal machine axis). The indicator and the corresponding grub screw d7 must be purchased separately. For further information on the indicators see the pages of articles K650 and K660 [page 362 363 and page 364 365].

(*) With adapter KS08050.T01 you can mount the indicator K650050.

Lateral insert:

Brass insert with threaded through hole.

Lateral handle:

Revolving handle art. M144 [page 400].

Locking handwheel:

Cylindrical handwheel G793-36 with threaded stud [page 249]. Black (RAL 9011). ATTENTION: dimension Q2 of the locking handwheel must be chosen by the customer based on the dimensions of the machinery on which the handwheel is applied. For model K903-130 the locking handwheel is replaced by the wing nut L751-32 [page 383].

Fixing method:

For fixing systems, or execution of keyways or square holes, please refer to the technical notes attached to the catalogue [page 814].

Special Requests:

- Upon request and for a minimum of 50 pieces inserts can be supplied with hole d1 with tolerance H7 and black oxide treated finish. Add letters ZB to the standard code. Example: K903100.T050D1001PZB.
- Upon request and for special quantities inserts can be supplied with custom hole diameter d1.
- Upon request and for special quantities inserts can be supplied in different materials/with different coatings.
- **The indicator must be ordered separately.**
- Upon request and for special quantities it is possible to change the indicator seat.

Combinations Diameters/Indicators:

d5=52.4 --> K650050

d5=87.4 --> K650080 or K660080

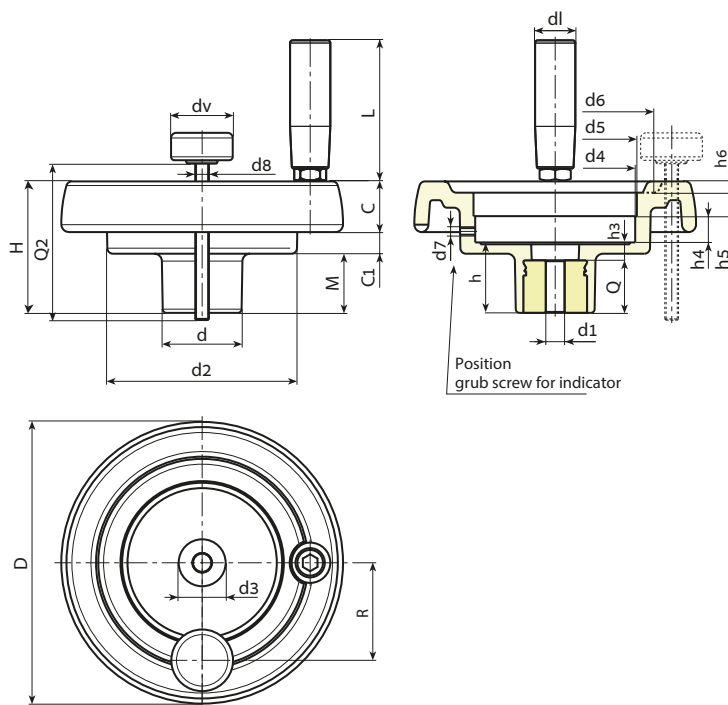

Position grub screw for indicator

Stock availability as % (🛒)
90% (●) - 40% (●) - 5% (●)

art.	D	H	d	d2	M	C	C1	d3	d4	d5	d6	d7	h	h3	h4	h5	h6	R	d8	d1	L	Dm	d1H10	Q	🛒	
K903130.T080P6,801P	129	64.5	42	100	27.5	23	14	29	85.7	87.4*	90	M6	34	10	13.5	12.5	5	54	M8	21	65	20	6.8	24	426	
K903150.T080P6,801P	149	69	42	101	31	25.5	12.5	29	85.7	87.4*	106	M6	37	9	13.5	12.5	6.5	57	M8	23	76	20	6.8	28	555	
K903175.T080P6,801P	175	72	40	115	28.5	32	11.5	25	85.7	87.4*	126.5	M6	38	10	12.5	14	8	60	M8	25	86	20	6.8	28	782	
K903200.T080P6,801P	199	71	46	137	24	32	15	29	123	87.4	144	M6	34	11	13.5	12.5	10	74	M8	25	86	22	6.8	23	950	

Attention: For a minimum of 50 pieces the diameter d1 can be customised (hole tolerance H10 galvanised and H7 black-oxide treated).

Dm = Maximum obtainable diameter for subsequent machining (widening).

Q2 = Upon request.

dv = 36 mm. (K903130 dv=32 mm)