

K900

SOLID CONTROL HANDWHEEL WITH INDICATOR SEAT



Materials:

Reinforced and stabilized polyamide.
Resistant to oils and greases.

Surface finish:

Satin.

Colour:

Black (RAL 9011).

Insert:

Galvanised steel insert with smooth through bore (tolerance H10).

Mountable indicator:

Use gravity position indicators models K650 or K660. The indicator can be only used in a vertical position (horizontal machine axis). The indicator and the corresponding grub screw d7 must be purchased separately. For further information on the indicators see the pages of articles K650 and K660 [page 362 363 and page 364 365].
Resistant to oils and greases.

(*) With adapter KS08050.T01 you can mount the indicator K650050.

Fixing method:

For fixing systems, or execution of keyways or square holes, please refer to the technical notes attached to the catalogue [page 814].

Special Requests:

- Upon request and for a minimum of 50 pieces inserts can be supplied with hole d1 with tolerance H7 and black oxide treated finish. Add letters ZB to the standard code. Example: K900100.T050D1001PZB.
- Upon request and for special quantities inserts can be supplied with custom hole diameter d1.
- Upon request and for special quantities inserts can be supplied in different materials/with different coatings.
- **The indicator must be ordered separately.**
- Upon request and for special quantities it is possible to change the indicator seat.

Combinations Diameters/Indicators:

d5=52.4 --> K650050

d5=87.4 --> K650080 or K660080

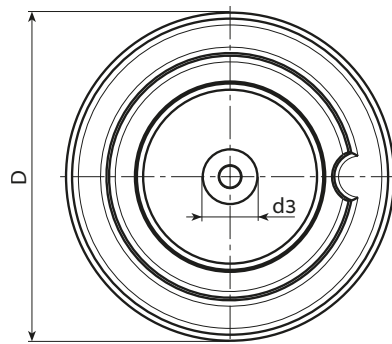
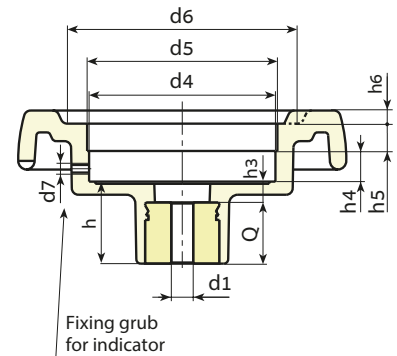
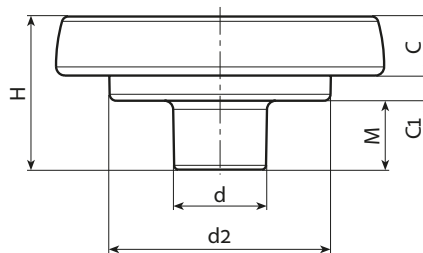

Stock availability as % (🛒)

90% (●) - 40% (●) - 5% (●)

art.	D	H	d	d2	M	C	C1	d3	d4	d5	d6	d7	h	h3	h4	h5	h6	Dm	d1H10	Q	g
K900087.T050P5,801P	86	53	32	62	21	17	15	20	50.8	52.4	63	M6	26.5	6.5	11.5	12	3	12	5.8	20	155
K900100.T050P6,801P	99	55.5	32	63	23.5	20.5	11.5	20	50.8	52.4	68	M6	29	9	11.5	12	3.5	12	6.8	20	170
K900130.T080P6,801P	129	64.5	42	100	27.5	23	14	29	85.7	87.4*	90	M6	34	10	13.5	12.5	5	20	6.8	24	350
K900150.T080P6,801P	149	69	42	101	31	25.5	12.5	29	85.7	87.4*	106	M6	37	9	13.5	12.5	6.5	20	6.8	28	430
K900175.T080P6,801P	175	72	40	115	28.5	32	11.5	25	85.7	87.4*	126.5	M6	38	10	12.5	14	8	20	6.8	28	650
K900200.T080P6,801P	199	71	46	137	24	32	15	29	123	87.4*	144	M6	34	11	13.5	12.5	10	22	6.8	23	810

Attention: For a minimum of 50 pieces the diameter d1 can be customised (hole tolerance H10 galvanised and H7 black-oxide treated).
Dm = Maximum obtainable diameter for subsequent machining (widening).