

J142

UNIVERSAL LOCK FOR 3 MM WINGED TUBE KEY



Materials:

- (1) Die-cast zamak lock body M19 (stator) and rotor. 3 mm winged tubular key.
- (2) Elastic washer d. 24x1 with bore d. 19.4.
- (3) Steel hexagon lock nut M19x1.
- (4) Steel locking lever. (Qn design N flat - Qe design E bent outwards).
- (5) Conical steel elastic washer d. 12x1.5.
- (6) Steel Phillips dome head screw M5x8.

Surface finish:

- (1) Nickel-plated.
- (2-5) Black oxide treated.
- (3-4-6) Standard blue galvanising.

Key (optional):

- (7) Red plastic key, Article J09050.TP0316.
- ATTENTION: The key is not supplied. To be ordered separately.

Rotation:

90°.

Special Requests:

- None.

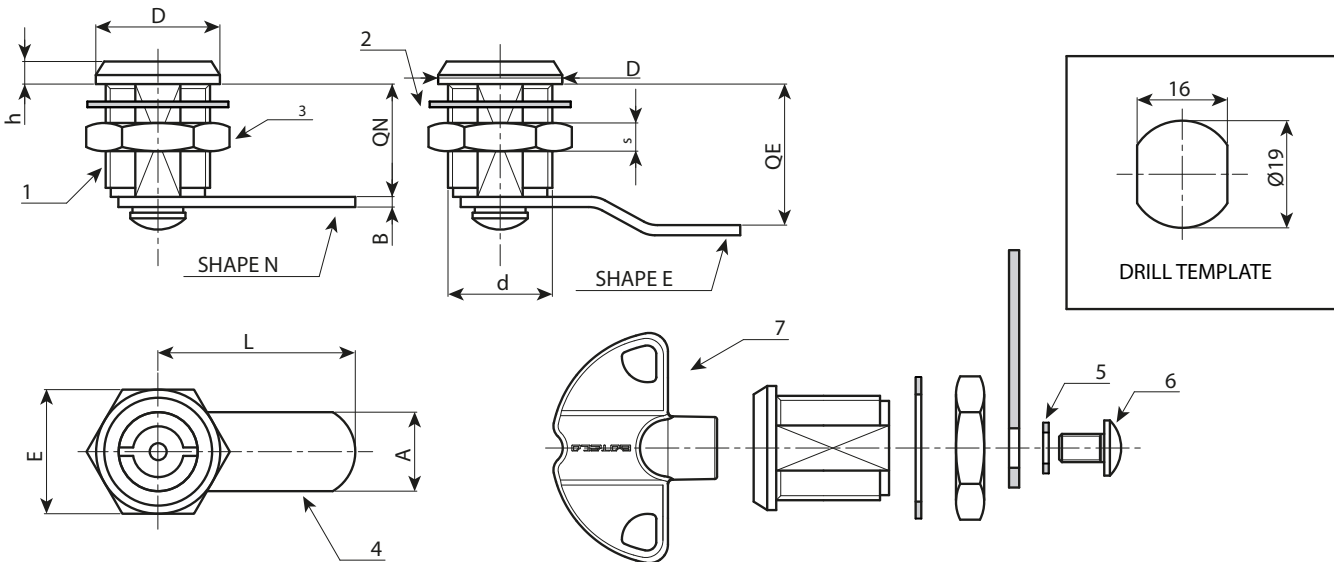

Stock availability as % (🛒)
90% (●) - 40% (●) - 5% (●)

Art.	d	L	Qn	Qe	D	h	A	B	E	S	🔒
J142019.ZN0335X20	M19	35	20	-	22	4	14	2.5	22	5	48
J142019.ZE0335X22	M19	35	-	22	22	4	14	2.5	22	5	49
J142019.ZE0330X25	M19	30	-	25	22	4	14	2.5	22	5	47
J142019.ZE0339X29	M19	39	-	29	22	4	14	2.5	22	5	49
J142019.ZE0335X37	M19	35	-	37	22	4	14	2.5	22	5	51

Arbel Agencies LTD.



11 Ba'alei Hamelacha st. Qiryat Bialik P.O.B 1095, ZIP 2751311, ISRAEL
+972(0)48736969 ☎ +972(0)48730708 📠 info@arbel-ltd.com 📧 www.arbel-ltd.com 🌐

