

J124

NEW



C10

UL94 HB

RoHS COMPLIANT

UNIVERSAL QUARTER TURN PLASTIC CAM LOCK M22 THREAD WITH WING PIN SOCKET KEY

Materials:

- (1) Lock body M22x1.5 (stator) in reinforced PA6.6 polyamide. Resistant to oils and greases.
- (2) Groove shaped for wing pin key, in reinforced PA6.6 polyamide.
- (3) Die-cast zamak hexagon lock nut M22x1,5.
- (4) Rubber gasket.
- (5) Steel cam (E=0 straight, E=2,4,6,8,10 formed out, E=-2 formed in).
- (6) Phillips steel fixing screw M6x10.

Surface finish:

- (1) Satin.
- (2-3-4-5-6) Smooth.

Colour:

- (1) Black (RAL 9011).
- (2-3-4-5-6) Standard galvanising.

Key (optional):

Red polyamide (PA6) key art. J090.
ATTENTION: The key is not supplied. To be ordered separately. [page 316].



Rotation: 90°

Special Requests:

- On request it is possible to have the lock complete with its key. Add the letter C at the end of the main code.
- Cams available for the locks with Q=18 and L=45:
 - E=-4 (J12422.T03E-4X4501),
 - E=-2 (J12422.T03E-2X4501),
 - E=+2 (J12422.T05E02X4501),
 - E=+4 (J12422.T03E04X4501),
 - E=+6 (J12422.T03E06X4501),
 - E=+8 (J12422.T05E08X4501),
 - E=+10 (J12422.T03E10X4501),
 - E=+12 (J12422.T03E12X4501),

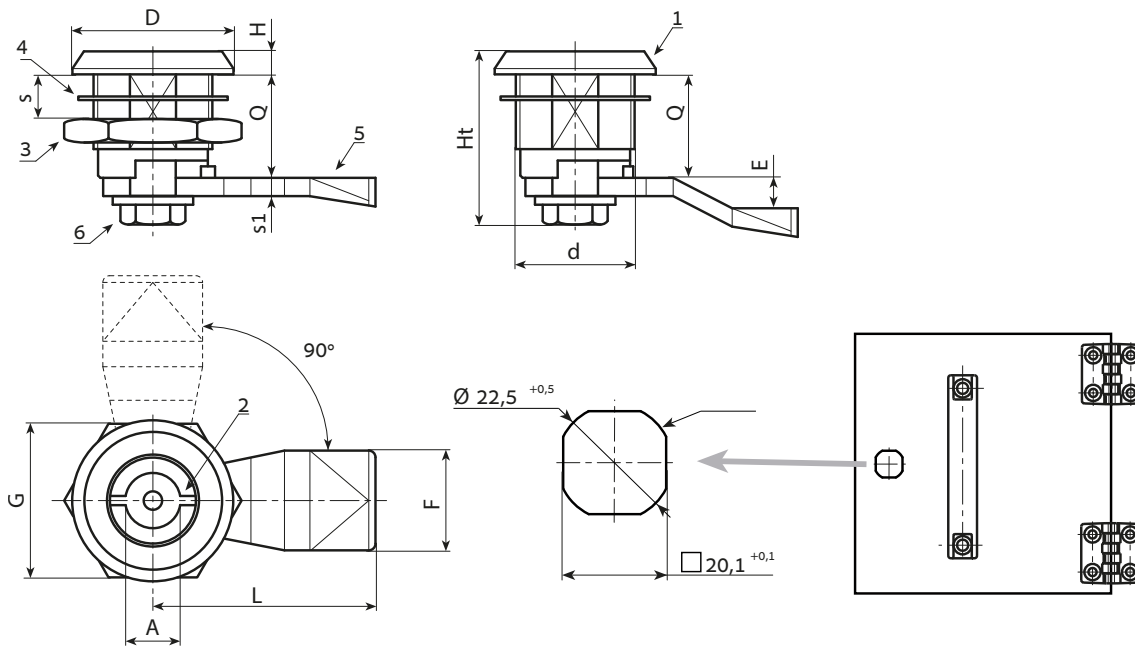

Stock availability as % (🛒)
 90% (●) - 40% (●) - 5% (●)

Art.	A	d	D	L	Q	E	F	G	Ht	H	S(max.)	s1	🛒	Key
J12422.T03E00X4501	3	M22	28	45	18	0	19	27	31,5	4	8	4	-	J090050.TP0316
J12422.T05E00X4501	5	M22	28	45	18	0	19	27	31,5	4	8	4	-	J090050.TP0516

Arbel Agencies LTD.



11 Ba'alei Hamelacha st. Qiryat Bialik P.O.B 1095, ZIP 2751311, ISRAEL
 +972(0)48736969 ☎ +972(0)48730708 📠 info@arbel-ltd.com 📧 www.arbel-ltd.com 🌐

