

# I109

## PUSH-FIT CONICAL KNOB WITH HOLE



### Materials:

Reinforced polyamide.  
Resistant to oils and greases.

### Surface finish:

Satin.

### Colour:

Black (RAL 9011).

### Hole:

Blind smooth bore, with deformable fixing ribs, obtained by moulding the plastic.

### Fixing method:

Push-fit.

### Special requests:

- Upon request and for special quantities available in the colours indicated in the chart (ATTENTION: reduced range for measures marked (\*)) [page ].

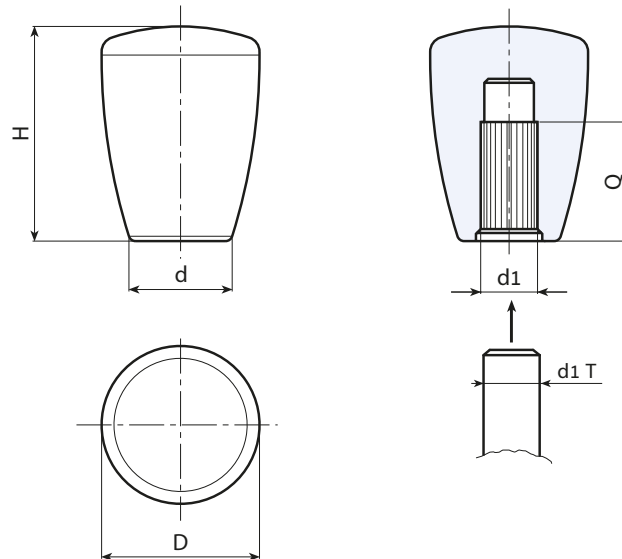

Stock availability as % (🛒)  
90% (●) - 40% (●) - 5% (●)

🛒	art.	D	H	d	d1 T	d1	Q	🛒
●	I10921.TG0501	21	28	13	+0 -0,048	5	16	13
●	I10925.TG0601	25	34	17	+0 -0,048	6	24	16
●	I10925.TG0801	25	34	17	+0 -0,058	8	24	16
●	I10925.TG1001	25	34	17	+0 -0,058	10	24	14
●	I10932.TG0801	32	43	21	+0 -0,058	8	30	36
●	I10932.TG1001	32	43	21	+0 -0,058	10	30	34
●	I10932.TG1201	32	43	21	+0 -0,070	12	30	30
●	I10943.TG1001	43	58	27	+0 -0,058	(*) 10	36	80
●	I10943.TG1201	43	58	27	+0 -0,070	(*) 12	36	78
●	I10943.TG1401	43	58	27	+0 -0,070	(*) 14	36	76
●	I10943.TG1501	43	58	27	+0 -0,070	(*) 15	36	74