

G735



4-LOBE HANDWHEEL WITH ELONGATED HUB AND THREADED STUD

Materials:

Reinforced polyamide. Resistant to oils and greases.

Surface finish:

Satin.

Colour:

Black (RAL 9011).

Inserts:

Galvanised steel threaded stud (thread tolerance 6g).

Special requests:

- Upon request and for special quantities inserts can be supplied with customised lengths.
- Upon request and for special quantities inserts can be supplied in different materials.
- Upon request and for special quantities handwheels can be supplied with custom hubs.

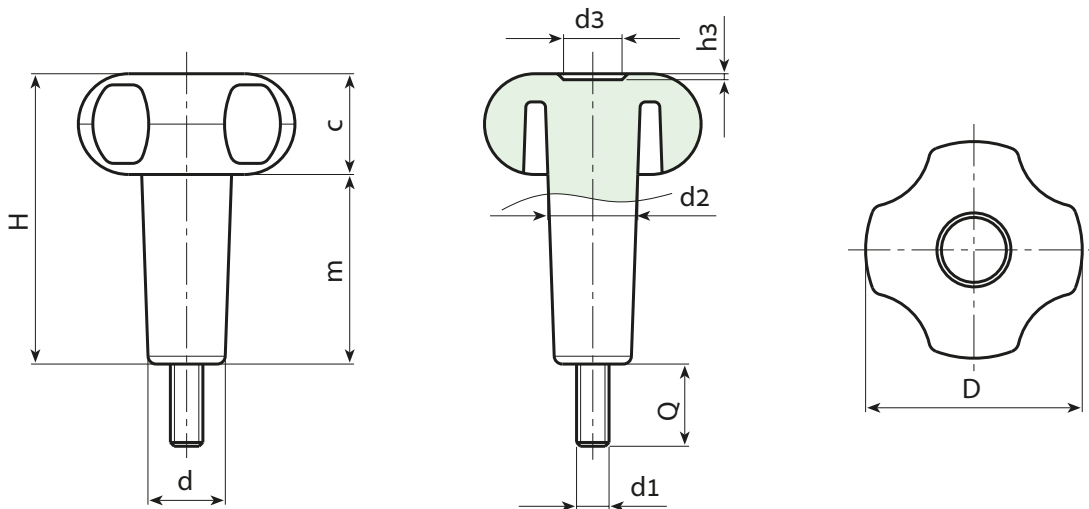

Stock availability as % (🛒)
90% (●) - 40% (●) - 5% (●)

🛒	art.	D	H	m	d	c	d2	d3	h3	LM	d1 _{6g}	Q	🛒
●	G73530.T35M06X1501	30	47	33.5	13.5	14	15	12	2	65	M6	15	23
●	G73530.T35M08X3001	30	47	33.5	13.5	14	15	12	2	65	M8	30	36
●	G73540.T35M08X2001	41	54	35	16.5	19	17	12	3	80	M8	20	49
●	G73540.T35M10X1501	41	54	35	16.5	19	17	12	3	80	M10	15	54
●	G73550.T40M08X1501	52	61	39	17.5	22	19	14	2.5	90	M8	15	60
●	G73550.T40M10X4001	52	61	39	17.5	22	19	14	2.5	90	M10	40	82
●	G73550.T50M08X..01	52	71	49	18	22	20.5	14	2.5	80	M8	A.R.	75
●	G73550.T60M08X3001	52	80	58	18	22	21	14	2.5	70	M8	30	86
●	G73560.T60M08X..01	59	83	58	23	25	24	24	4	75	M8	A.R.	115
●	G73560.T60M10X4001	59	83	58	23	25	24	24	4	75	M10	40	138
●	G73560.T80M10X..01	59	103	78	23	25	24	24	4	55	M10	A.R.	150

LM = Maximum mouldable length.

A.R. = Customised stud length available for a minimum of 100 pieces.

Enter the selected stud length in place of the two dots . . in the item code.