

# G630



## 4 LOBE HANDWHEEL WITH INDEXED INSERT (PUSH TO USE) AND THREADED INSERT

### Materials:

(3-4) Special high resistance glass fiber reinforced technopolymer.  
Resistant to oils and greases.

### Surface finish:

Satin.

### Colour:

(3-4) Black. (RAL 9011).

### Central fixing button:

(1) Red polyamide button (RAL 3000 code 16).

### Alternative handwheel and button colour:

Orange (RAL 2004 code 02).  
Blue (RAL 5015 code 07).  
Yellow (RAL 1021 code 10).  
Red (RAL 3000 code 16).  
Green (RAL 6024 code 17).  
Grey (RAL 7035 cod. 13).  
Black (RAL 9001 code 01).

### Inserts:

Brass insert with female threaded hole (thread tolerance 6H).

### Spring:

Stainless steel spring (Aisi 302).

### Special requests:

- Upon request and for special quantities inserts can be supplied in different materials.
- Upon request and for special quantities available in the colours indicated in the chart [page].

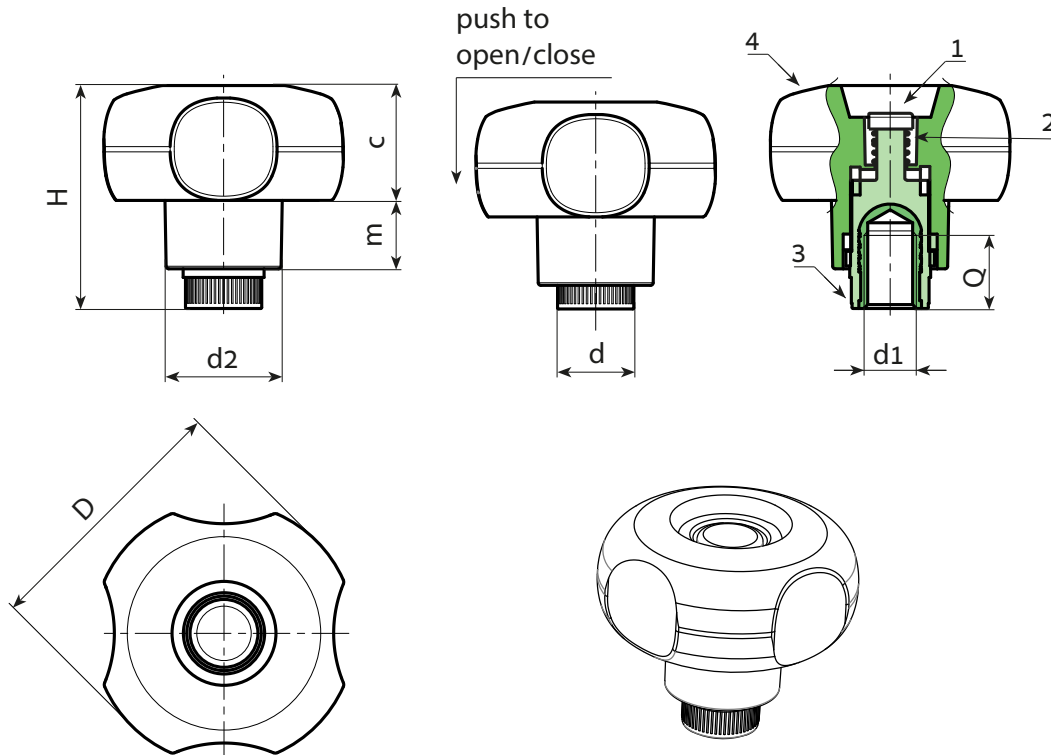

Stock availability as % (🛒)  
90% (●) - 40% (●) - 5% (●)

🛒	art.	D	H	d2	d	m	c	d1 <sub>6H</sub>	Q	🛒
●	G63050.TM060116	49	42.5	22	15	13	22	M6	14	37
●	G63050.TM080116	49	42.5	22	15	13	22	M8	14	37
●	G63050.TM100116	49	42.5	22	15	13	22	M10	14	38