

F664 F764



STAR HANDWHEEL WITH STEEL HUB AND THREADED STUD

Materials:

Reinforced polyamide. Resistant to oils and greases.

Surface finish:

Satin.

Colour:

Black (RAL 9011).

Inserts:

Galvanised steel threaded stud (thread tolerance 6g).

Hub:

Solid Hub

Special requests:

- Upon request and for special quantities inserts can be supplied with customised lengths.
- Upon request and for special quantities inserts can be supplied in different materials.
- Upon request and for special quantities available in the colours indicated in the chart on page .

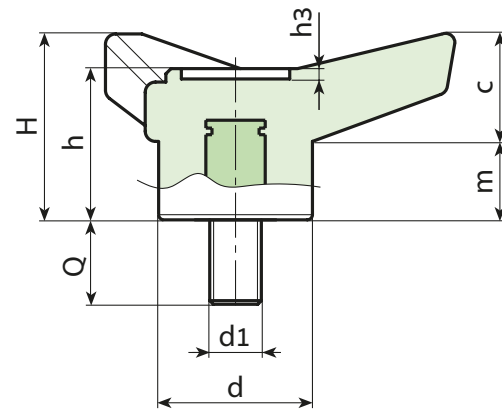
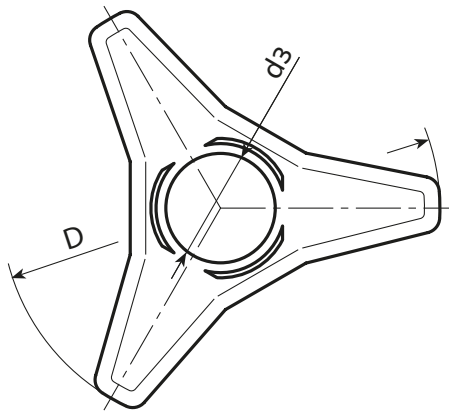

Version F764: with lightweight hub

Stock availability as % (🛒)
90% (●) - 40% (●) - 5% (●)

art.	D	H	h	d	c	m	d2	d3	h3	LM	d1 _{6g}	Q	g
F764085.TM08X..01	85	37	30.5	30	21	16	18	21	2	60	M8	20-30-40	61-65-69
F764085.TM10X..01	85	37	30.5	30	21	16	18	21	2	60	M10	20-30-40	66-74-80
F764085.TM12X..01	85	37	30.5	30	21	16	18	21	2	60	M12	20-30	83-89
F764105.TM10X..01	105	46	37.5	35	26	19	20	25	2	80	M10	30-50	116-122
F764105.TM12X..01	105	46	37.5	35	26	19	20	25	2	80	M12	30-50	121-136
F764105.TM14X..01	105	46	37.5	35	26	19	20	25	2	80	M14	A.R.	-
F764125.TM12X..01	125	54	44	42.5	31	23	26	28.5	2	100	M12	A.R.	-
F764125.TM14X..01	125	54	44	42.5	31	23	26	28.5	2	100	M14	A.R.	-

Enter the selected stud length in place of the two dots . . in the item code.

A.R. = Upon request, for a minimum of 150 pieces.

LM = Maximum mouldable length.

Version F664: with solid hub

art.	D	H	h	d	c	m	d3	h3	LM	d1 _{6g}	Q	g
F664045.TM06X..01	45	21	18	16	11	10	11	1	60	M6	20-30	14-17
F664045.TM08X..01	45	21	18	16	11	10	11	1	60	M8	20-25-30	19-20,5-22
F664045.TM10X..01	45	21	18	16	11	10	11	1	60	M10	A.R.	-
F664065.TM08X..01	65	28	23.5	22	16.5	11.5	15.5	1.5	80	M8	20-25-30	36-37,5-39
F664065.TM10X..01	65	28	23.5	22	16.5	11.5	15.5	1.5	80	M10	20-30-50	43-47-55
F664065.TM12X..01	65	28	23.5	22	16.5	11.5	15.5	1.5	80	M12	A.R.	-
F664085.TM08X..01	85	37	30.5	30	21	16	21	2	60	M8	20-25-30	61-65-69
F664085.TM10X..01	85	37	30.5	30	21	16	21	2	60	M10	25-30-40	66-74-80
F664085.TM12X..01	85	37	30.5	30	21	16	21	2	60	M12	20-30-40	83-87-94
F664105.TM10X..01	105	46	37.5	35	26	19	25	2	80	M10	20-30-40	113-116-122
F664105.TM12X..01	105	46	37.5	35	26	19	25	2	80	M12	30-50	121-136
F664125.TM18X..01	125	54	44	42.5	31	23	28.5	2	100	M18	A.R.	-

Enter the selected stud length in place of the two dots . . in the item code.

A.R. = Upon request, for a minimum of 150 pieces.

LM = Maximum mouldable length.