

F662



3-LOBE SOLID HANDWHEEL WITH INSERT AND SMOOTH BORE

Materials:

Reinforced polyamide.
Resistant to oils and greases.

Surface finish:

Satin.

Colour:

Black (RAL 9011).

Inserts:

Galvanised steel insert with blind smooth bore (bore tolerance H10).

Special Requests:

- Upon request and for special quantities inserts can be supplied with custom hole diameter d1.
- Upon request and for special quantities inserts can be supplied in different materials.
- Upon request and for special quantities available in the colours indicated in the chart (attention: reduced range) [page].

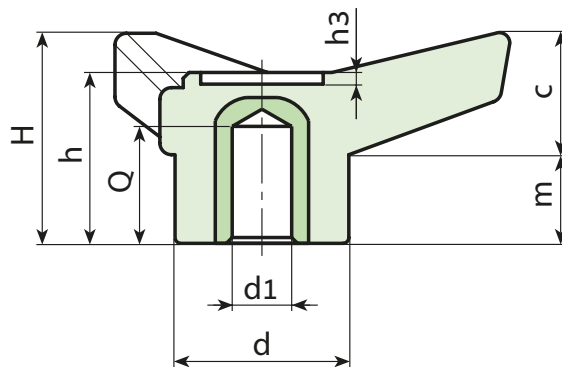
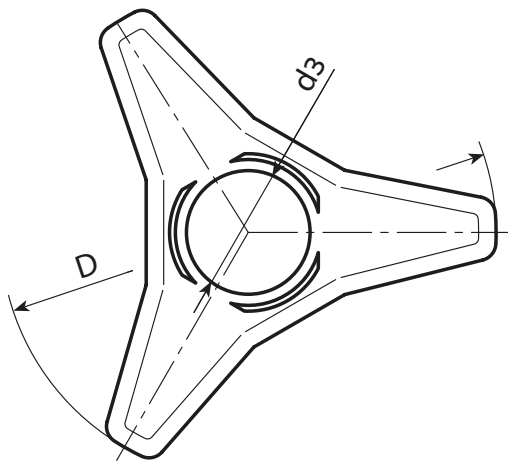

Stock availability as % (🛒)
90% (●) - 40% (●) - 5% (●)

🛒	Art.	D	H	h	d	c	m	d3	h3	dm	d1H10	Q	📦
●	F662045.TD0601	45	21	18	16	11	10	11	1	-	6	8	14
●	F662065.TD0501	65	28	23.5	22	16.5	11.5	15.5	1.5	10	5	13	36
●	F662065.TD1001	65	28	23.5	22	16.5	11.5	15.5	1.5	10	10	13	34
●	F662085.TD0501	85	37	30.5	30	21	16	21	2	16	5	19	72
●	F662085.TD1001	85	37	30.5	30	21	16	21	2	16	10	19	70
●	F662085.TD1201	85	37	30.5	30	21	16	21	2	16	12	19	69
●	F662085.TD1401	85	37	30.5	30	21	16	21	2	16	14	19	65
●	F662105.TD0501	105	46	37.5	35	26	19	25	2	18	5	24	100
●	F662105.TD1201	105	46	37.5	35	26	19	25	2	18	12	24	98
●	F662105.TD1401	105	46	37.5	35	26	19	25	2	18	14	24	95
●	F662105.TD1601	105	46	37.5	35	26	19	25	2	18	16	24	90
●	F662125.TD0801	125	54	44	42.5	31	23	28	2	22	8	26	192

Attention: for a minimum of 50 pieces the diameter d1 can be produced with the requested dimensions with H10 tolerance.
Dm = Maximum obtainable diameter for subsequent machining (widening).