

E521



INDEXED CRANK HANDLE WITH SMOOTH BORE INSERT AND FOLDING HANDLE

Material:

Reinforced polyamide. Resistant to oils and greases.

Surface finish:

Satin.

Colour:

Black (RAL 9011).

Inserts:

Galvanised steel insert with blind smooth bore (bore tolerance H10).

Lateral insert:

Brass insert with threaded through hole.

Spring:

Stainless steel spring (Aisi 302).

Fixing screw:

Black oxide treated steel screw with slotted head.

Lateral handle:

Revolving, folding handle art. M136 [page ()].

Special requests:

- Upon request and for special quantities inserts can be supplied in different materials.
- Upon request and for special quantities crank handle body available in the colours indicated in the chart [page].

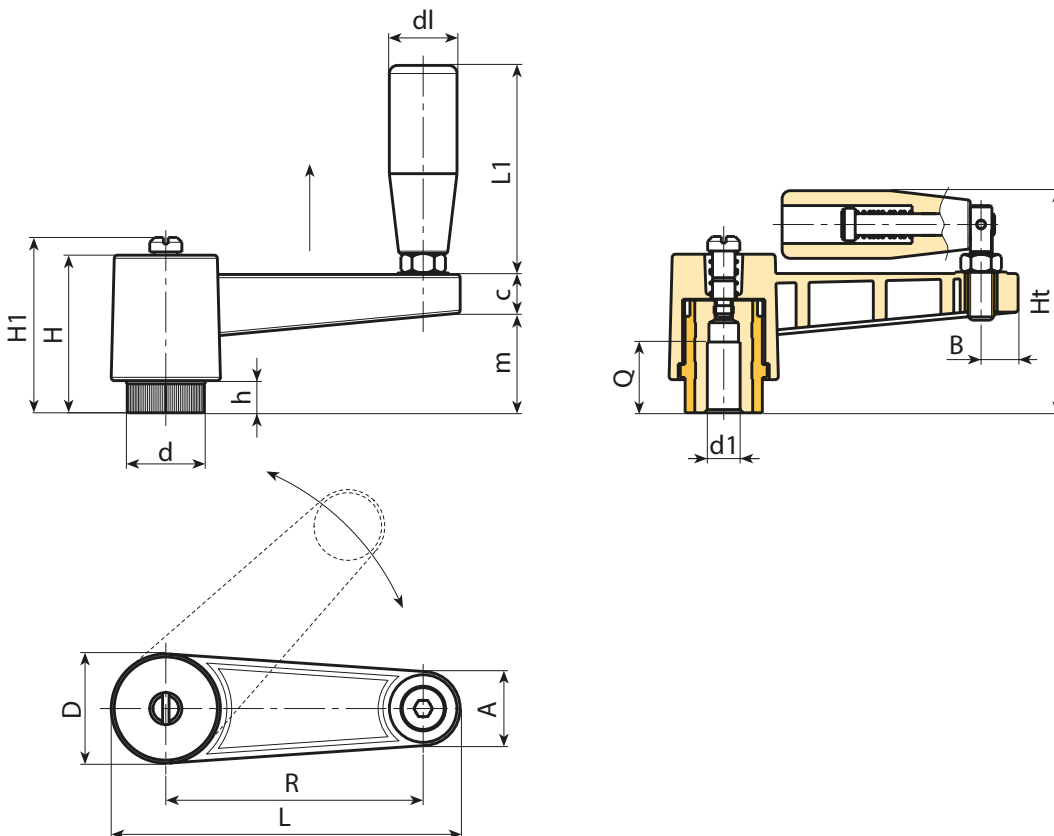

Stock availability as % (🛒)

90% (●) - 40% (●) - 5% (●)

🛒	Art.	L	R	H	D	d	m	c	A	B	h	H1	Ht	d1 _{H10}	Q	dl	L1	g
●	E521065.TP0501	87,5	65	46	27	19	29	13	17	9	10	-	67,5	5	22	20	54	105
●	E521080.TP0501	109	80	50	34	24,5	33	13	22	12	11	54	75	5	28	23,5	76	190
●	E521110.TP0501	139	110	50	34	24,5	33	13	22	12	11	54	75	5	28	23,5	76	220