

E216



CRANK HANDLE WITH SMOOTH BORE INSERT AND REVOLVING HANDLE

Material:

Reinforced polyamide.
Resistant to oils and greases.

Surface finish:

Satin.

Colour:

Black (RAL 9011).

Central cap:

Grey polyamide (RAL 7035 code 13).

Alternative Cap colours:

Orange (RAL 2004 code 02).
Red (RAL 3000 code 16).
Blue (RAL 5015 code 07).
Green (RAL 6024 code 17).
Yellow (RAL 1021 code 10).
Black (RAL 9011 code 01).

Inserts:

Galvanised steel insert with smooth through bore (tolerance H10).

Lateral insert:

Brass insert with threaded through hole.

Lateral handle:

E216: Revolving handle art. M144 page ().

E221: Revolving handle art. M145 page ().

E222: Revolving handle art. M129 page ().

Special requests:

- Upon request and for special quantities inserts can be supplied with custom hole diameter d1.
- Upon request and for special quantities inserts can be supplied in different materials/with different coatings.
- Upon request and for special quantities available in the colours indicated in the chart [page].

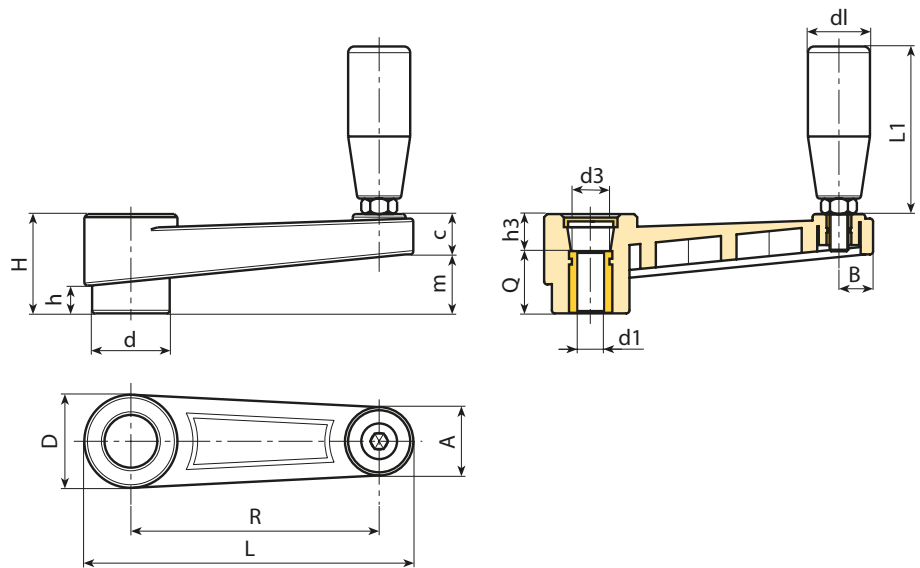

Stock availability as % (🛒)
90% (●) - 40% (●) - 5% (●)

🛒	Art.	L	R	H	D	d	m	c	A	B	h	d3	h3	dm	d1 _{H10}	Q	d1	L1	🛒
●	E216065.TP0501	88,5	65	30	27,5	22	17	13	20	9,5	8	14,5	10	12	5	20	19	54	96
●	E216065.TD1001	88,5	65	30	27,5	22	17	13	20	9,5	8	14,5	10	12	10	20	19	54	92
●	E216065.TD1201	88,5	65	30	27,5	22	17	13	20	9,5	8	14,5	10	12	12	20	19	54	89
●	E216080.TP0501	107	80	33,5	32	26	20,5	13	23	11	9	19,5	9,5	14	5	24	19	54	110
●	E216080.TD1001	107	80	33,5	32	26	20,5	13	23	11	9	19,5	9,5	14	10	24	19	54	105
●	E216080.TD1201	107	80	33,5	32	26	20,5	13	23	11	9	19,5	9,5	14	12	24	19	54	102
●	E216110.TD0801	140	110	39	35	29	25	14	24	12	11	19,5	11	14	8	28	21	66	160
●	E216110.TD1001	140	110	39	35	29	25	14	24	12	11	19,5	11	14	10	28	21	66	152
●	E216110.TD1201	140	110	39	35	29	25	14	24	12	11	19,5	11	14	12	28	21	66	148
●	E216140.TD0801	175	140	49	44	35,5	32	17	27	13	15,5	24	19	20	8	30	23,5	76	250
●	E216140.TD1201	175	140	49	44	35,5	32	17	27	13	15,5	24	19	20	12	30	23,5	76	242
●	E216140.TD1401	175	140	49	44	35,5	32	17	27	13	15,5	24	19	20	14	30	23,5	76	238
●	E216140.TD1601	175	140	49	44	35,5	32	17	27	13	15,5	24	19	20	16	30	23,5	76	232
●	E216185.TD0801	223	185	55	47,5	40	38,5	16,5	27	14	17	29,5	21	22	8	34	25,5	87	430
●	E216185.TD1201	223	185	55	47,5	40	38,5	16,5	27	14	17	29,5	21	22	12	34	25,5	87	400

Attention: For a minimum of 50 pieces the diameter d1 can be customised (hole tolerance H10 galvanised and H7 black-oxide treated).
Dm = Maximum obtainable diameter for subsequent machining (widening).

Arbel Agencies LTD.



11 Ba'alei Hamelacha st. Qiryat Bialik P.O.B 1095, ZIP 2751311, ISRAEL
+972(0)48736969 ☎ +972(0)48730708 📠 info@arbel-ltd.com 📧 www.arbel-ltd.com 🌐



E221



CRANK HANDLE WITH SMOOTH BORE INSERT AND REVOLVING HANDLE M145

General features:

All unspecified features are identical to basic item E216.

Inserts:

Galvanised steel insert with smooth through bore (tolerance H10).

Lateral handle:

Revolving handle art. M145 [page].



Art.	L	R	H	D	d	m	c	A	B	h	d3	h3	dm	d1 _{H10}	Q	dl	L1	g
E221065.TP0501	89	65	30	27,5	22	17	13	20	9,5	8	14,5	10	12	5	20	20	56	101
E221065.TD1001	89	65	30	27,5	22	17	13	20	9,5	8	14,5	10	12	10	20	20	56	107
E221065.TD1201	89	65	30	27,5	22	17	13	20	9,5	8	14,5	10	12	12	20	20	56	104
E221080.TP0501	107	80	33,5	32	26	20,5	13	23	11	9	19,5	9,5	14	5	24	20	56	125
E221080.TD1001	107	80	33,5	32	26	20,5	13	23	11	9	19,5	9,5	14	10	24	20	56	130
E221080.TD1201	107	80	33,5	32	26	20,5	13	23	11	9	19,5	9,5	14	12	24	20	56	127
E221110.TD0801	140	110	39	35	29	25	14	24	12	11	19,5	11	14	8	28	23,5	68	175
E221110.TD1001	140	110	39	35	29	25	14	24	12	11	19,5	11	14	10	28	23,5	68	172
E221110.TD1201	140	110	39	35	29	25	14	24	12	11	19,5	11	14	12	28	23,5	68	169
E221140.TD0801	175	140	49	44	35,5	32	17	27	13	15,5	24	19	20	8	30	25	77	263
E221140.TD1201	175	140	49	44	35,5	32	17	27	13	15,5	24	19	20	12	30	25	77	257
E221140.TD1401	175	140	49	44	35,5	32	17	27	13	15,5	24	19	20	14	30	25	77	253
E221140.TD1601	175	140	49	44	35,5	32	17	27	13	15,5	24	19	20	16	30	25	77	249
E221185.TD0801	223	185	55	47,5	40	38,5	16,5	27	14	17	29,5	21	22	8	34	26	86	440
E221185.TD1201	223	185	55	47,5	40	38,5	16,5	27	14	17	29,5	21	22	12	34	26	86	433

Attention: For a minimum of 50 pieces the diameter d1 can be customised (hole tolerance H10 galvanised and H7 black-oxide treated).

Dm = Maximum obtainable diameter for subsequent machining (widening).

E222



CRANK HANDLE WITH SMOOTH BORE INSERT AND REVOLVING HANDLE M129

General features:

All unspecified features are identical to basic item E216.

Inserts:

Galvanised steel insert with smooth through bore (tolerance H10).

Lateral handle:

Revolving handle art. M129 [page].



Art.	L	R	H	D	d	m	c	A	B	h	d3	h3	dm	d1 _{H10}	Q	dl	L1	g
E222065.TP0501	89	65	30	27,5	22	17	13	20	9,5	8	14,5	10	12	5	20	20	52	111
E222065.TD1001	89	65	30	27,5	22	17	13	20	9,5	8	14,5	10	12	10	20	20	52	117
E222065.TD1201	89	65	30	27,5	22	17	13	20	9,5	8	14,5	10	12	12	20	20	52	114
E222080.TP0501	107	80	33,5	32	26	20,5	13	23	11	9	19,5	9,5	14	5	24	20	52	135
E222080.TD1001	107	80	33,5	32	26	20,5	13	23	11	9	19,5	9,5	14	10	24	20	52	140
E222080.TD1201	107	80	33,5	32	26	20,5	13	23	11	9	19,5	9,5	14	12	24	20	52	136
E222110.TD0801	140	110	39	35	29	25	14	24	12	11	19,5	11	14	8	28	23,5	63	182
E222110.TD1001	140	110	39	35	29	25	14	24	12	11	19,5	11	14	10	28	23,5	63	179
E222110.TD1201	140	110	39	35	29	25	14	24	12	11	19,5	11	14	12	28	23,5	63	175
E222140.TD0801	175	140	49	44	35,5	32	17	27	13	15,5	24	19	20	8	30	25	72	271
E222140.TD1201	175	140	49	44	35,5	32	17	27	13	15,5	24	19	20	12	30	25	72	265
E222140.TD1401	175	140	49	44	35,5	32	17	27	13	15,5	24	19	20	14	30	25	72	261
E222140.TD1601	175	140	49	44	35,5	32	17	27	13	15,5	24	19	20	16	30	25	72	255
E222185.TD0801	223	185	55	47,5	40	38,5	16,5	27	14	17	29,5	21	22	08	34	26	82	450
E222185.TD1201	223	185	55	47,5	40	38,5	16,5	27	14	17	29,5	21	22	12	34	26	82	442

Attention: For a minimum of 50 pieces the diameter d1 can be customised (hole tolerance H10 galvanised and H7 black-oxide treated).

Dm = Maximum obtainable diameter for subsequent machining (widening).

Stock availability as % (🛒)
90% (●) - 40% (●) - 5% (●)