

D782

LIGHTWEIGHT CONTROL HANDWHEEL



Materials:

Reinforced polyamide.
Resistant to oils and greases.

Surface finish:

Satin.

Colour:

Black (RAL 9011).

Main insert:

Galvanised steel insert with smooth through bore (tolerance H10).

Fixing method:

For fixing systems, or execution of keyways or square holes, please refer to the technical notes attached to the catalogue [page 814].

Special requests:

- Upon request and for a minimum of 50 pieces inserts can be supplied with hole d1 with tolerance H7 and black oxide treated finish. Add letters ZB to the standard code. Example: D78280.TD1101PZB.
- Upon request and for special quantities inserts can be supplied with custom hole diameter d1.
- Upon request and for special quantities inserts can be supplied in different materials/with different coatings.
- Upon request and for special quantities available in the colours indicated in the chart [page 807].

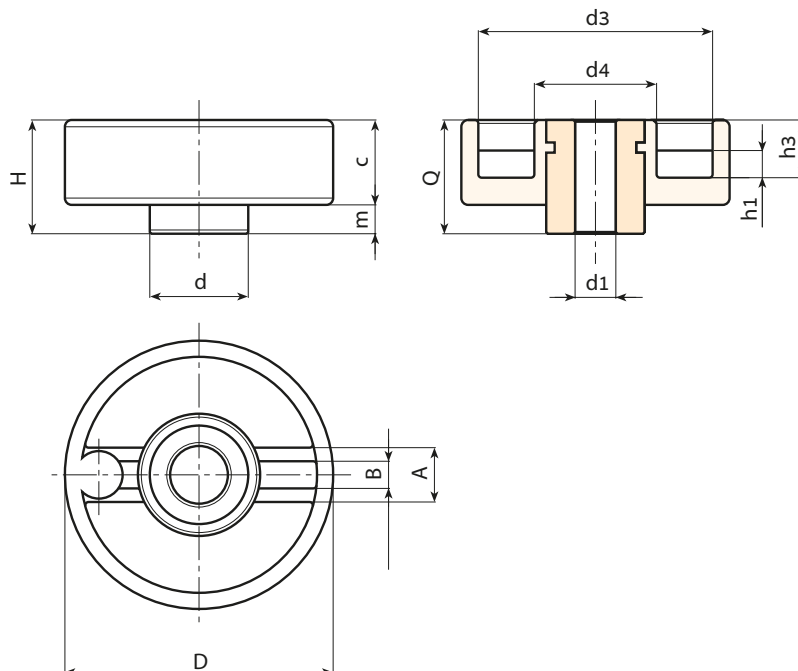

Stock availability as % (🛒)
90% (●) - 40% (●) - 5% (●)

🛒	Art.	D	H	d	c	m	h1	h3	A	B	d3	d4	Dm	d1 _{H10}	Q	📦
●	D78280.TD0801P	80	34	29	25	9	8	17	16	7.5	69	36	20	8	34	230

Attention: For a minimum of 50 pieces the diameter d1 can be customised (hole tolerance H10 galvanised and H7 black-oxide treated).
Dm = Maximum obtainable diameter for subsequent machining (widening).