

D604

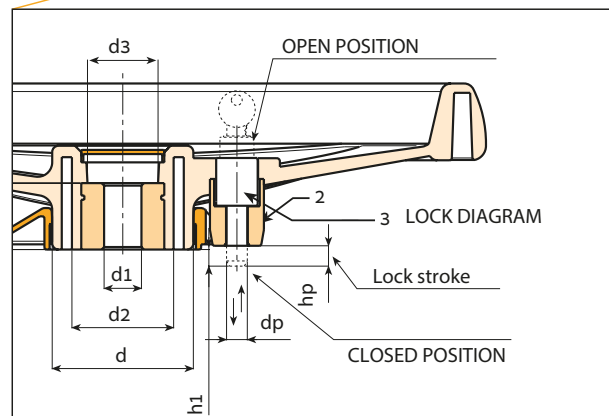

TWO-SPOKE HANDWHEEL WITH REVOLVING HANDLE AND KEY LOCK

This product type is a variation of our traditional handwheel D207-350. By simply adding a special assembly kit this product adapts to the requirements of a particular market: the mobile shelving market (mobile storage cabinets mounted on a trackway). This handwheel is used to move the shelving along the trackway. A fitted lock or locking piston serves to lock, stop, position the shelving units in certain positions.

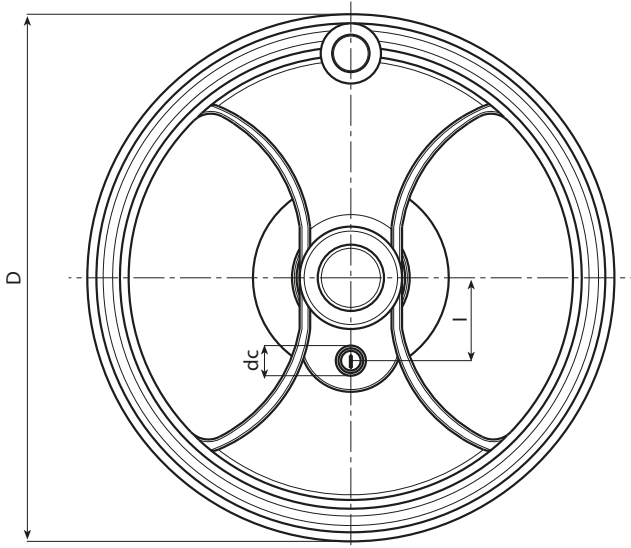
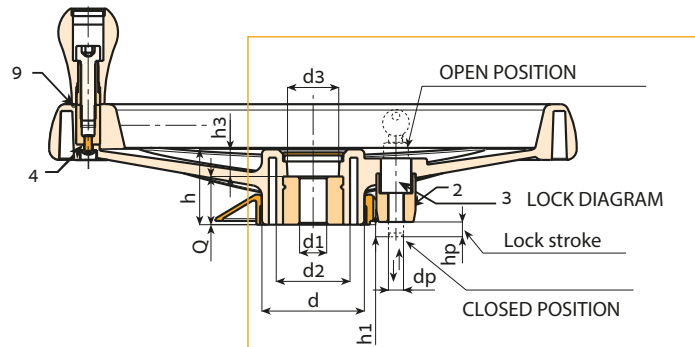
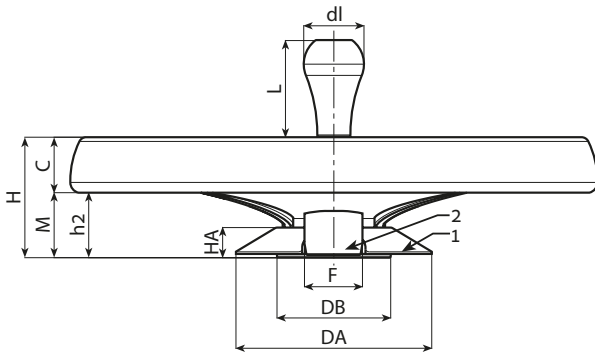

Stock availability as % (🛒)
 90% (●) - 40% (●) - 5% (●)

Art.	D	H	Ht	h	d	M	C	h2	h3	d2	d3	Dm
D604350.TD2001H	346	80	86	49.5	67.5	24	56	43.5	17.5	49	35	28

Dm = Maximum obtainable diameter for subsequent machining. (widening)
 A.R. = Upon request, for a minimum of 50 pieces.



Arbel Agencies LTD.
 11 Ba'alei Hamelacha st. Qiryat Bialik P.O.B 1095, ZIP 2751311, ISRAEL
 +972(0)48736969 ☎ +972(0)48730708 📠 info@arbel-ltd.com 🌐 www.arbel-ltd.com 🌐



D604



TWO-SPOKE HANDWHEEL WITH REVOLVING HANDLE AND KEY LOCK

Materials:

Reinforced and stabilized polyamide. Resistant to oils and greases.

Surface finish:

Satin.

Colour:

Black (RAL 9011).

Central cap:

Grey polyamide (RAL 7035 code 13).

Alternative cap colours:

Orange (RAL 2004 cod. 02).

Blue (RAL 5015 cod. 07).

Yellow (RAL 1021 cod. 10).

Red (RAL 3000 cod. 16).

Green (RAL 6024 cod. 17).

Black (RAL 9011 cod. 01).

Clamping lock kit:

(1) PA6+GF hole cover ring. Colour Black (RAL 9011). Push-fit assembly. Removable.

(2) PA6+GF piston holder. Colour Black (RAL 9011). Assembly with two self-tapping, galvanised steel screws, screwdriver head (TC) 3.5x30.

(3) Nickel plated lock. Two numbered keys provided. Key can be removed from either position. To close the handwheel push and turn the key by 90°. Lock stroke 10 mm. Useful projection of pin from handwheel 8 mm. Keys supplied secured to the handwheel rim.

Inserts:

Galvanised steel insert with smooth through bore (tolerance H10).

(4) Black-oxide treated hexagon socket button head screw ISO 7838 for fastening handle.

(9) Hexagonal black-oxide treated steel insert with threaded through hole.

Lateral handle:

Revolving handle M202 "Euromodel", black RAL 9011.

Handle cap in grey polyamide (RAL 7035 code 13).

Fixing method:

For fixing systems, or execution of keyways or square holes, please refer to the technical notes attached to the catalogue [page 814].

Special requests:

- Upon request and for a minimum of 50 pieces inserts can be supplied with hole d1 with tolerance H7 and black oxide treated finish. Add letters ZB to the standard code. Example: D604350.TD1001PZB.
- Upon request and for special quantities inserts can be supplied with custom hole diameter d1.
- Upon request and for special quantities inserts can be supplied in different materials/with different coatings.
- Upon request and for special quantities available in the colours indicated in the chart [page 807].



Stock availability as % (🛒)
90% (●) - 40% (●) - 5% (●)

Art.	d1 _{H10}	Q	I	dc	h1	dp	hp	DA	HA	DB	F	g
D604350.TD2001H	20	32	55	20	8	10	10	131	20	76	38	1800

Dm = Maximum obtainable diameter for subsequent machining. (widening)

A.R. = Upon request, for a minimum of 50 pieces.