

# D208



## TWO-SPOKE CONTROL HANDWHEEL WITH REVOLVING FOLDING HANDLE

### Materials:

Reinforced and stabilized polyamide. Resistant to oils and greases.

Surface finish: Satin.

Colour: Black (RAL 9011).

### Central cap:

Grey polyamide (RAL 7035 code 13).

### Alternative cap colours:

Orange (RAL 2004 cod. 02).  
 Blue (RAL 5015 cod. 07).  
 Yellow (RAL 1021 cod. 10).  
 Red (RAL 3000 cod. 16).  
 Green (RAL 6024 cod. 17).  
 Black (RAL 9011 cod. 01).

### Main insert:

Galvanised steel insert with smooth through bore (tolerance H10).

### Lateral insert:

Brass insert with threaded through hole.

(+) Hexagonal black-oxide treated steel insert with threaded through hole. Fixed with black-oxide treated hexagon socket button head screw ISO 7838.

### Lateral handle:

Revolving, folding handle art. M136 [page 405].

### Hub:

Solid Hub.

(\*) Lightweight hub.

### Fixing method:

For fixing systems, or execution of keyways or square holes, please refer to the technical notes attached to the catalogue [page 814].

### Special requests:

- Upon request and for a minimum of 50 pieces inserts can be supplied with hole d1 with tolerance H7 and black oxide treated finish. Add letters ZB to the standard code. Example: D208160.TD1501PZB.
- Upon request and for special quantities inserts can be supplied with custom hole diameter d1.
- Upon request and for special quantities inserts can be supplied in different materials/with different coatings.
- Upon request and for special quantities spoke handwheels, handles and caps are available in the colours indicated in the chart (reduced range) [page 807].

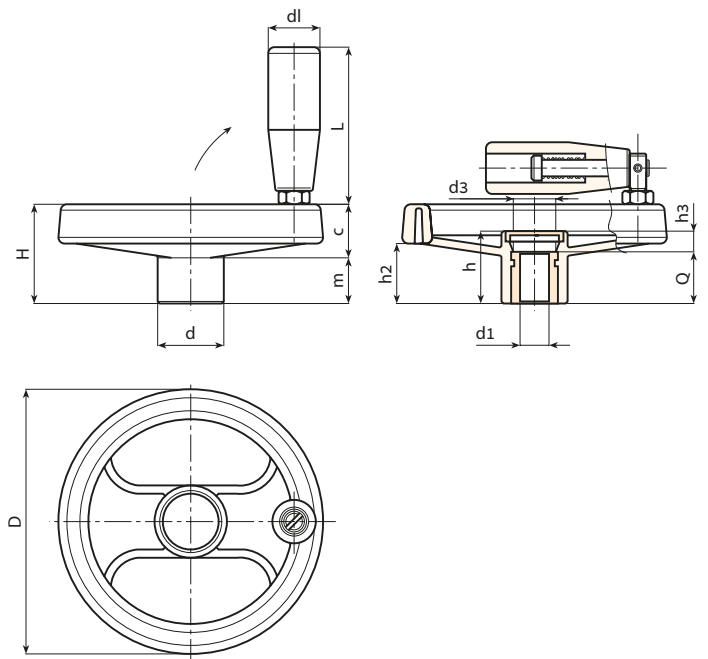

Stock availability as % (🛒)  
 90% (●) - 40% (●) - 5% (●)

🛒	Art.	D	H	h	d	m	c	h2	h3	d3	dl	L	Dm	d1H10	Q	🛒
●	D208080.TP0501P	80	34	26	24.5	16	18	20	6	16	20	56	12	5	20	135
●	D208080.TD0801P	80	34	26	24.5	16	18	20	6	16	20	56	12	8	20	132
●	D208080.TD1001P	80	34	26	24.5	16	18	20	6	16	20	56	12	10	20	129
●	D208100.TP0501P	99	43	33	28	20	23	26.5	9	16	20	56	16	5	24	192
●	D208100.TD0801P	99	43	33	28	20	23	26.5	9	16	20	56	16	8	24	189
●	D208100.TD1001P	99	43	33	28	20	23	26.5	9	16	20	56	16	10	24	186
●	D208100.TD1201P	99	43	33	28	20	23	26.5	9	16	20	56	16	12	24	183
●	D208130.TD0501P	129	50	36	32	21	29	32	12	26	25	76	18	5	24	311
●	D208130.TD0801P	129	50	36	32	21	29	32	12	26	25	76	18	8	24	308
●	D208130.TD1001P	129	50	36	32	21	29	32	12	26	25	76	18	10	24	305
●	D208130.TD1201P	129	50	36	32	21	29	32	12	26	25	76	18	12	24	302
●	D208160.TD0801P	159	57	40.5	40	22	35	34	8.5	26	25	76	22	8	32	460
●	D208160.TD1401P	159	57	40.5	40	22	35	34	8.5	26	25	76	22	14	32	452
●	D208160.TD2001P	159	57	40.5	40	22	35	34	8.5	26	25	76	22	20	32	448
●	D208200.TD0801P	198	61.5	39.5	51	17.5	44	33	7.5	26	25	76	22	(*)8	32	704
●	D208200.TD1601P	198	61.5	39.5	51	17.5	44	33	7.5	26	25	76	22	(*)16	32	694
●	D208200.TD2001P	198	61.5	39.5	51	17.5	44	33	7.5	26	25	76	22	(*)20	32	689
●	D208250.TD0801P	252	70	47	55.5	24	46	39	11	24	26	97	28	(*)8	36	1080
●	D208250.TD2001P	252	70	47	55.5	24	46	39	11	24	26	97	28	(*)20	36	1065
●	D208350.TD0801P	346	80	49.5	67.5	24	56	43.5	17.5	35	26	97	30	(*)(+)*8	32	1690

Attention: For a minimum of 50 pieces the diameter d1 can be customised (hole tolerance H10 galvanised and H7 black-oxide treated).  
 Dm = Maximum obtainable diameter for subsequent machining (widening).