

C980



SOLID CONTROL HANDWHEEL WITH REVOLVING/FOLDING HANDLE AND LOCKING KNOB

Materials:

Reinforced and stabilized polyamide.
Resistant to oils and greases.

Surface finish:

Satin.

Handwheel and handle colour:

Black (RAL 9011).

Central cap:

Grey polyamide (RAL 7035 code 13).

Main insert:

Galvanised steel insert with smooth through bore (tolerance H10).

Lateral insert:

Brass insert with threaded through hole.

Lateral handle:

Revolving, folding handle art. M136 [page].

Locking knob:

Black cylindrical knob Ral 9011 art. G793-36 with threaded stud [page]. Caution: the R and Q2 dimensions of the locking knob must be chosen by the customer according to the dimensions of the machinery on which the solid handwheel will be installed.

Fixing method:

For fixing systems, or execution of keyways or square holes, please refer to the technical notes attached to the catalogue [page].

Special requests:

- On request and with a minimum of 50 pieces, the inserts can be supplied with the hole d1 with H7 tolerance and black-oxide finish. Add the letters ZB to the standard code. Example: C980125.TD1001PZB.
- Upon request and for special quantities inserts can be supplied with custom hole diameter d1.
- Upon request and for special quantities inserts can be supplied in different materials/with different coatings.

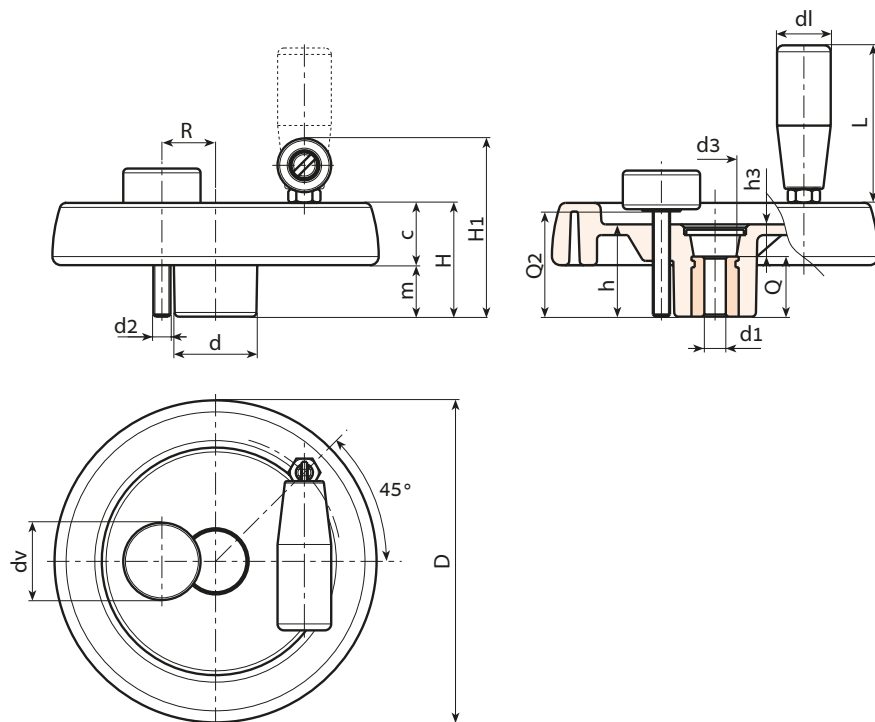

Stock availability as % (🛒)
90% (●) - 40% (●) - 5% (●)

🛒	Art.	D	H	H1	h	d	m	c	d3	h3	R	d2	Q2	d1	L	Dm	d1 _{H10}	Q	📦
●	C980100.TP0501P	100	39	63	34	30	18.5	20.5	16	10	20	M6	A.R.	20	56	16	5	24	295
●	C980125.TP0501P	125	44	74	37	36	20	24	26	13	22÷25	M6	A.R.	25	76	18	5	24	420
●	C980150.TD0801P	150	54	89	44	38	25	29	26	12	25÷28	M8	A.R.	26	89	22	8	32	730
●	C980175.TD0801P	173	57	92	47	40	25.5	31.5	26	15	26÷36	M8	A.R.	26	89	22	8	32	885
●	C980200.TD0801P	202	59	94	49	44	24	35	27	13	28÷42	M8	A.R.	26	97	28	8	36	1100
●	C980250.TD0801P	249	68	100	58	59	29	39	36	22	36÷50	M8	A.R.	26	97	28	8	36	1640

Attention: For a minimum of 50 pieces the diameter d1 can be customised (hole tolerance H10 galvanised and H7 black-oxide treated).
Dm = Maximum obtainable diameter for subsequent machining (widening).
dv = 36 mm. A.R. = On request.