

C197

UPDATE



PA6
+G.F.

UL94
HB



SOLID CONTROL HANDWHEEL WITH REVOLVING HANDLE

Materials:

Reinforced and stabilized polyamide.
Resistant to oils and greases.

Surface finish:

Satin.

Colour:

Black (RAL 9011).

Central cap:

Grey polyamide (RAL 7035 code 13).

Alternative cap colours:

Orange (RAL 2004 code 02).
Blue (RAL 5015 code 07).
Yellow (RAL 1021 code 10).
Red (RAL 3000 code 16).
Green (RAL 6024 code 17).
Black (RAL 9011 code 01).

Main insert:

Galvanised steel insert with smooth through bore (tolerance H10).

Lateral insert:

Brass insert with threaded through hole.

Lateral handle:

C197: Revolving handle art. M144 (page).
C193: Revolving handle art. M145 (page).
C194: Revolving handle art. M129 (page).
C195: Revolving handle art. M202 (page).

Fixing method:

For fixing systems, or execution of keyways or square holes, please refer to the technical notes attached to the catalogue [page].

Special requests:

- On request and with a minimum of 50 pieces, the inserts can be supplied with the hole d1 with H7 tolerance and black-oxide finish. Add the letters ZB to the standard code. Example: C197100.TD1001PZB.
- Upon request and for special quantities inserts can be supplied with custom hole diameter d1.
- Upon request and for special quantities inserts can be supplied in different materials/with different coatings.
- Upon request and for special quantities handwheels, handles and caps are available in the colours indicated in the chart (reduced range) [page].

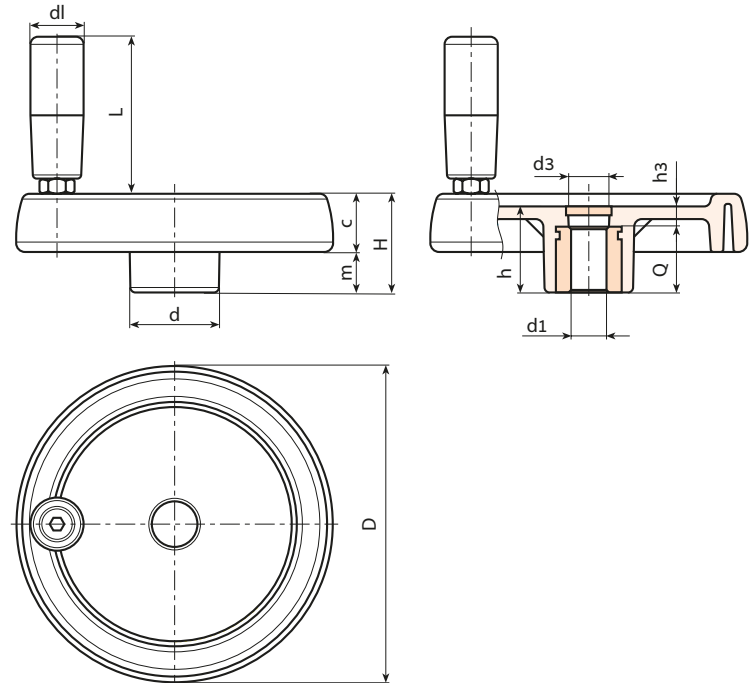

Stock availability as % (🛒)
90% (●) -40% (●) -5% (●)

🛒	Art.	D	H	h	d	m	c	d3	h3	Dm	d1H10	Q	g
●	C197080.TP0501P	81	33	29	25	16	17	16	9	12	5	20	130
●	C197080.TD0801P	81	33	29	25	16	17	16	9	12	8	20	129
●	C197080.TD1001P	81	33	29	25	16	17	16	9	12	10	20	127
●	C197100.TP0501P	100	39	34	30	18.5	20.5	16	10	16	5	24	192
●	C197100.TD0801P	100	39	34	30	18.5	20.5	16	10	16	8	24	192
●	C197100.TD1001P	100	39	34	30	18.5	20.5	16	10	16	10	24	190
●	C197100.TD1201P	100	39	34	30	18.5	20.5	16	10	16	12	24	188
●	C197125.TP0501P	125	44	37	36	20	24	26	13	18	5	24	351
●	C197125.TD0801P	125	44	37	36	20	24	26	13	18	8	24	345
●	C197125.TD1201P	125	44	37	36	20	24	26	13	18	12	24	340
●	C197125.TD1401P	125	44	37	36	20	24	26	13	18	14	24	335
●	C197150.TD0801P	150	54	44	38	25	29	26	12	22	8	32	588
●	C197150.TD1201P	150	54	44	38	25	29	26	12	22	12	32	580
●	C197150.TD1401P	150	54	44	38	25	29	26	12	22	14	32	577
●	C197150.TD1601P	150	54	44	38	25	29	26	12	22	16	32	570
●	C197175.TD0801P	173	57	47	40	25.5	31.5	26	15	22	8	32	770
●	C197175.TD1601P	173	57	47	40	25.5	31.5	26	15	22	16	32	755
●	C197175.TD2001P	173	57	47	40	25.5	31.5	26	15	22	20	32	751
●	C197200.TD0801P	202	59	49	44	24	35	27	13	28	8	36	980
●	C197200.TD2001P	202	59	49	44	24	35	27	13	28	20	36	960
●	C197250.TD0801P	249	68	58	59	29	39	36	22	28	8	36	1530

Attention: For a minimum of 50 pieces the diameter d1 can be customised (hole tolerance H10 galvanised and H7 black-oxide treated).
Dm = Maximum obtainable diameter for subsequent machining (widening).

Arbel Agencies LTD.



11 Ba'alei Hamelacha st. Qiryat Bialik P.O.B 1095, ZIP 2751311, ISRAEL
+972(0)48736969 ☎ +972(0)48730708 📠 info@arbel-ltd.com 📧 www.arbel-ltd.com 🌐



C193



SOLID CONTROL HANDWHEEL WITH REVOLVING HANDLE M145

Art.	D	H	h	d1	L	Dm	d1H10	Q	
C193080.TP0501P	81	33	29	20	55	12	5	20	135
C193100.TP0501P	100	39	34	20	55	16	5	24	220
C193125.TP0501P	125	44	37	23	66	18	5	24	370
C193150.TD0801P	150	54	44	25	76	22	8	32	594
C193175.TD0801P	173	57	47	25	87	22	8	32	750
C193200.TD0801P	202	59	49	27	96	28	8	36	965
C193250.TD0801P	249	68	58	27	96	28	8	36	1500

Attention: For a minimum of 50 pieces the diameter d1 can be customised (hole tolerance H10 galvanised and H7 black-oxide treated).
Dm = Maximum obtainable diameter for subsequent machining (widening).

Lateral handle:
C193: Revolving handle art. M145 (page).

C194



SOLID CONTROL HANDWHEEL WITH REVOLVING HANDLE M129

Art.	D	H	h	d1	L	Dm	d1H10	Q	
C194080.TP0501P	81	33	29	20	52	12	5	20	145
C194100.TP0501P	100	39	34	20	52	16	5	24	235
C194125.TP0501P	125	44	37	23	62	18	5	24	350
C194150.TD0801P	150	54	44	25	72	22	8	32	610
C194175.TD0801P	173	57	47	25	81	22	8	32	755
C194200.TD0801P	202	59	49	27	93	28	8	36	975
C194250.TD0801P	249	68	58	27	93	28	8	36	1520

Attention: For a minimum of 50 pieces the diameter d1 can be customised (hole tolerance H10 galvanised and H7 black-oxide treated).
Dm = Maximum obtainable diameter for subsequent machining (widening).

Lateral handle:
C194: Revolving handle art. M129 (page).

C195



SOLID CONTROL HANDWHEEL WITH REVOLVING HANDLE M202

Art.	D	H	h	d1	L	Dm	d1H10	Q	
C195150.TD0801P	150	54	44	40	64	22	8	32	610
C195175.TD0801P	173	57	47	40	64	22	8	32	750
C195200.TD0801P	202	59	49	40	64	28	8	36	960
C195250.TD0801P	249	68	58	40	64	28	8	36	1490

Attention: For a minimum of 50 pieces the diameter d1 can be customised (hole tolerance H10 galvanised and H7 black-oxide treated).
Dm = Maximum obtainable diameter for subsequent machining (widening).

Lateral handle:
C195: Revolving handle art. M202 (page).

Stock availability as % ()
90% (●) - 40% (●) - 5% (●)