

| REVISIONS |      |      |       |                           |          |          |
|-----------|------|------|-------|---------------------------|----------|----------|
| SHEET     | ZONE | REV. | ECO   | DESCRIPTION               | DATE     | APPROVED |
| 1         | ALL  | A    | 50253 | UPDATE DWG TO 2017 FORMAT | 2/6/2018 | HRC      |

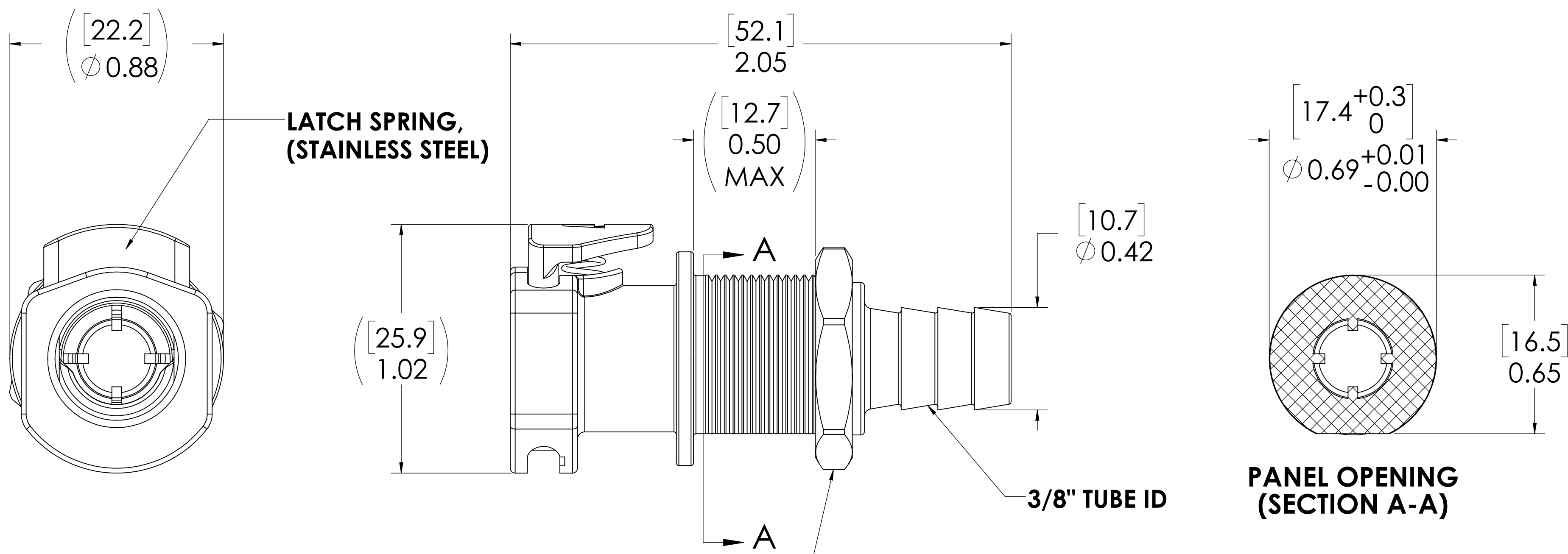
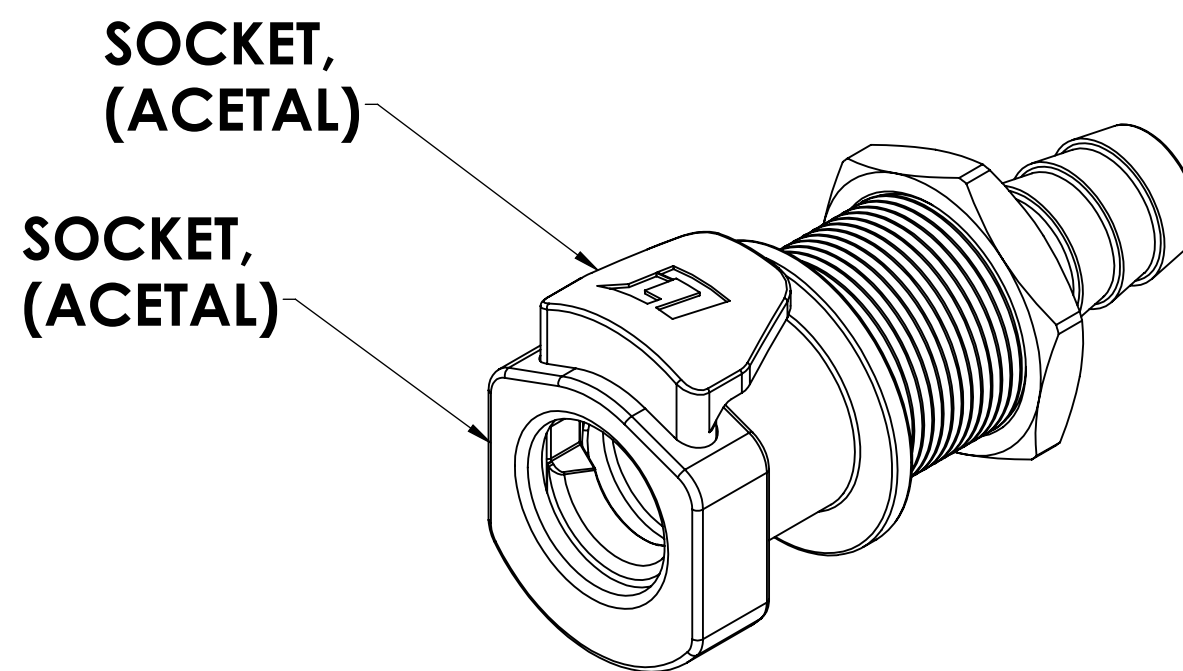

**LATCH SPRING,  
(STAINLESS STEEL)**

**PANEL NUT  
(NICKEL PLATED BRASS,  
11/16" HEX)  
PACKAGED SEPARATELY**

**3/8" TUBE ID**

**PANEL OPENING  
(SECTION A-A)**

**FOR REFERENCE ONLY**

- NOTES:**
- MATERIAL: ACETAL
  - COLOR: NATURAL WHITE

|  |            |          |           |   |
|--|------------|----------|-----------|---|
| <small>UNLESS OTHERWISE SPECIFIED:<br/>DIMENSIONS ARE IN INCHES<br/>TOLERANCES:<br/>FRACTIONAL ± 1/32<br/>ANGULAR: MACH ± 0.5 BEND ± 2<br/>ONE PLACE DECIMAL ± 0.1<br/>TWO PLACE DECIMAL ± 0.01<br/>THREE PLACE DECIMAL ± 0.005<br/>TWO PLACE DUAL (mm) [± 0.12]</small> | DRAWN      | RDA      | 7/12/2017 |   |
|  | CHECKED    | HRC      | 8/4/2017  |   |
|  | ENG APPR.  | HRC      | 02-06-18  |   |
|  | MFG APPR.  | BDB      | 02-06-18  |   |
| PRODUCTION   | RK         | 02-06-18 |           | <b>PART NO: 50AC-S3-06</b><br><b>DESCRIPTION: LinkTech 50AC Series Panel Mt. Female, Non-valved, 375 HB, Natural Acetal</b> |
| COMMENTS:  |            |          |           | <b>SIZE DWG. NO. REV</b><br><b>C 50AC500046 A</b>   |
|  | SCALE: NTS | WEIGHT:  |           | SHEET 1 OF 1  |