

REVISIONS						
SHEET	ZONE	REV.	ECO	DESCRIPTION	DATE	APPROVED
1	ALL	A	50253	UPDATE DWG TO CURRENT FORMAT & STANDARDS	10/18/2018	HRC

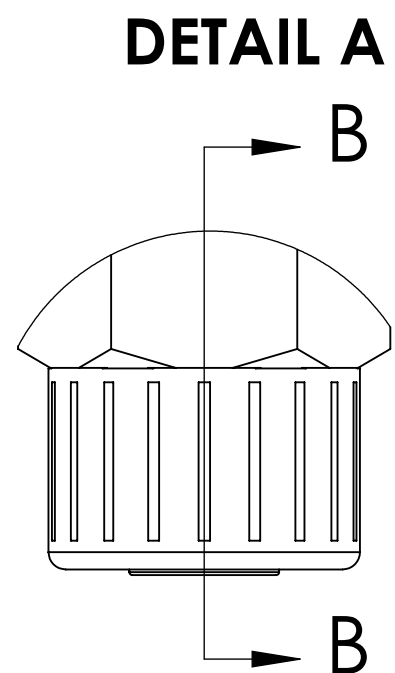

SECTION B-B

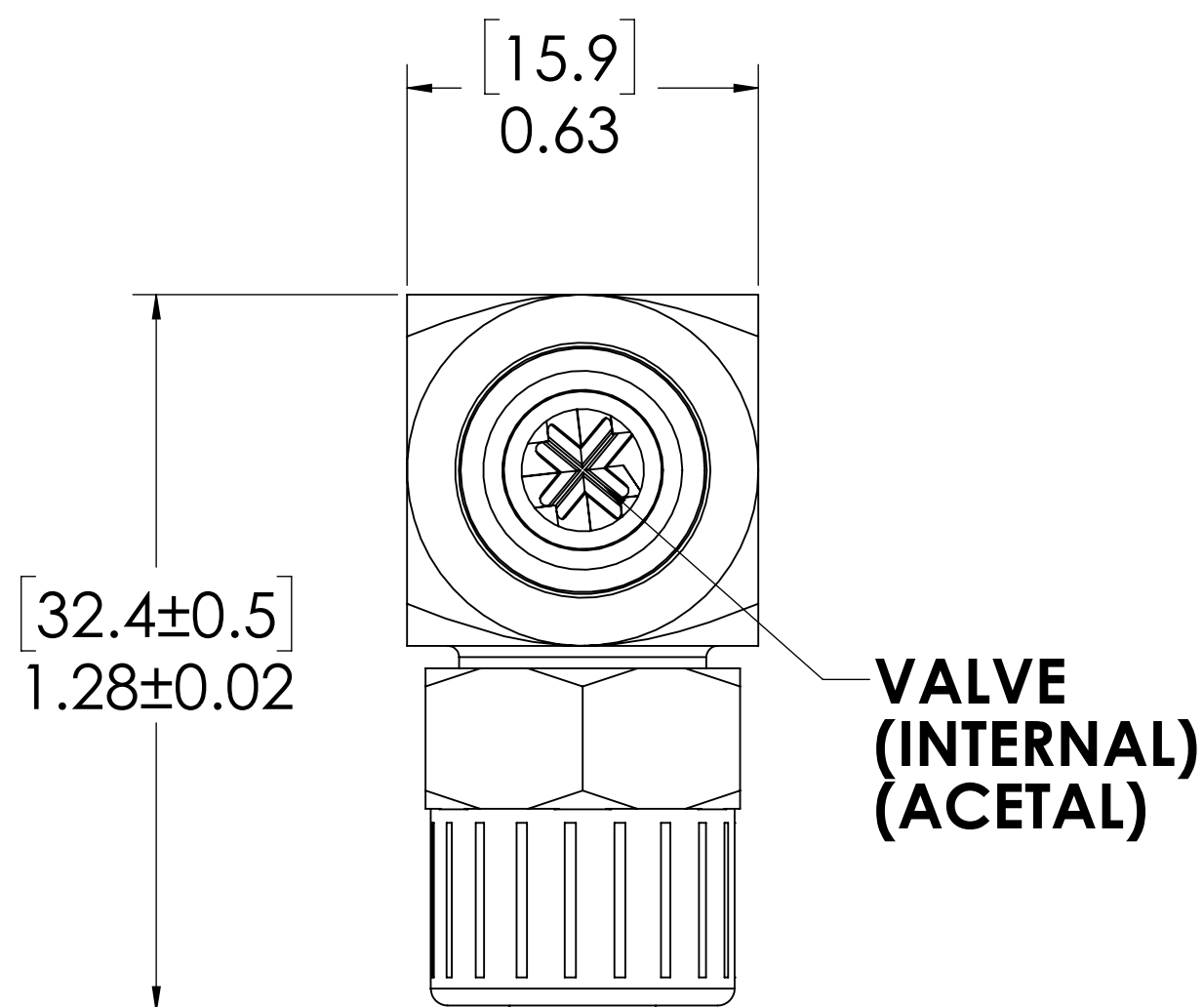
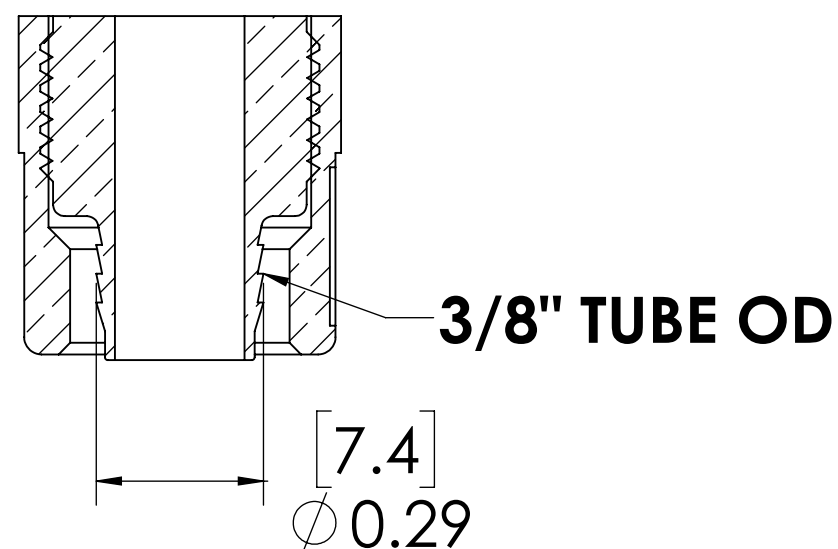

**PLUG
(BRASS, NICKEL &
CHROME PLATED)**

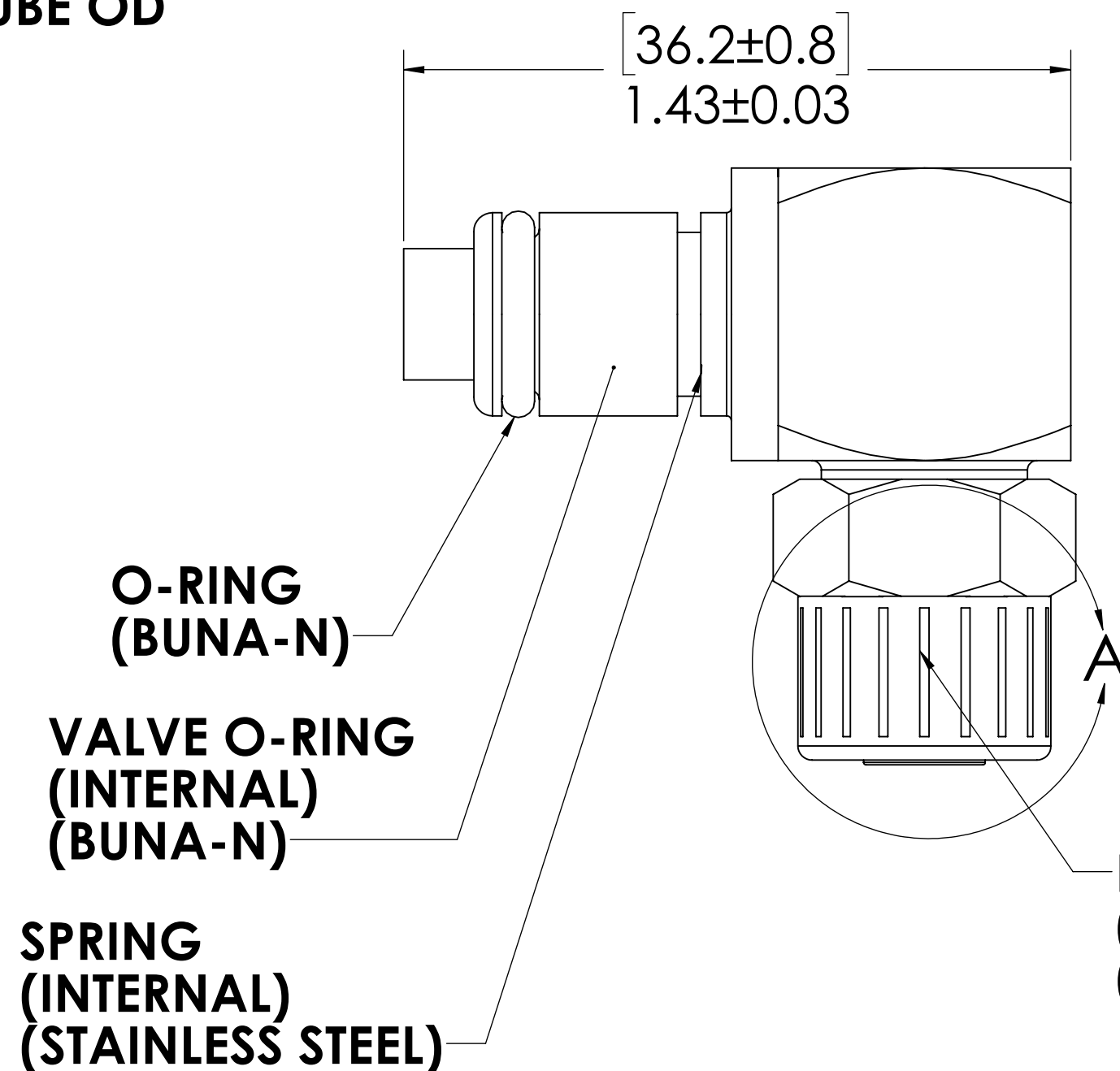
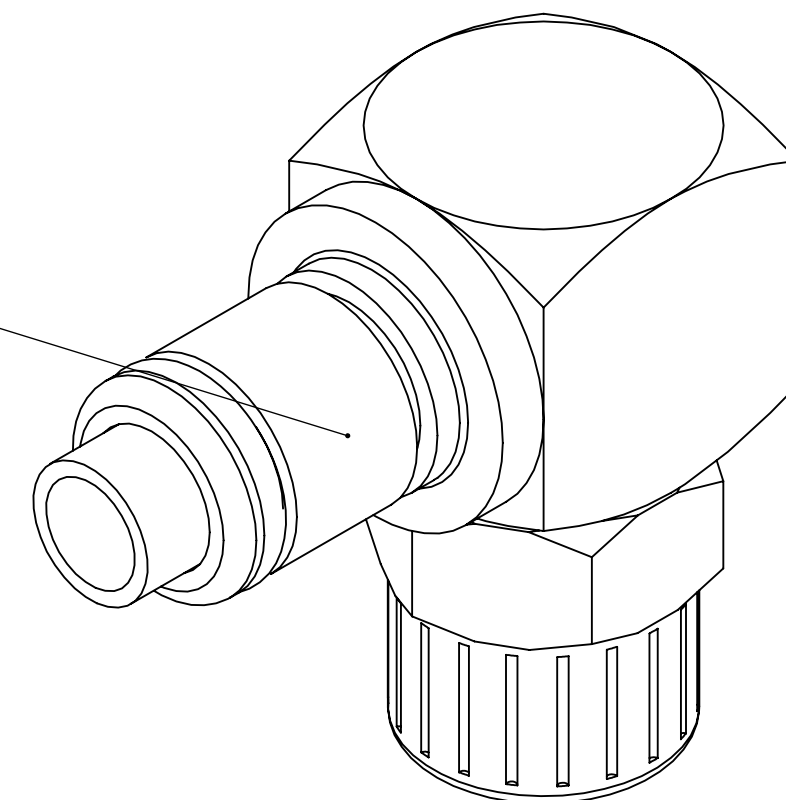

NOTES:

- MATERIAL: BRASS
- FINISH: CHROME
- O-RING MATERIAL: BUNA-N
- O-RINGS LUBRICATED WITH FOOD GRADE SILICONE OIL, 350 CST.

FOR REFERENCE ONLY

<small>UNLESS OTHERWISE SPECIFIED: DIMENSIONS ARE IN INCHES TOLERANCES: FRACTIONAL ± 1/32 ANGULAR: MACH ± 0.5 BEND ± 2 ONE PLACE DECIMAL ± 0.1 TWO PLACE DECIMAL ± 0.01 THREE PLACE DECIMAL ± 0.005 TWO PLACE DUAL (mm) [±0.12]</small>	DRAWN	LDM	1/18/2018	
	CHECKED	HRC	1/18/2018	
	ENG APPR.	HRC	10/18/18	
	MFG APPR.	BDB	10/18/18	
PRODUCTION	LS	10/18/18		PART NO: 40CBV-PB10-06 DESCRIPTION: LinkTech 40CB Series Elbow Male, Valved, 3/8" PTF, Chrome Brass
<small>PROPRIETARY AND CONFIDENTIAL THE INFORMATION CONTAINED IN THIS DRAWING IS THE SOLE PROPERTY OF LINKTECH LLC. ANY REPRODUCTION OR DISCLOSURE IN PART OR AS A WHOLE WITHOUT THE WRITTEN PERMISSION OF LINKTECH LLC IS STRICTLY PROHIBITED.</small>				SCALE: NTS WEIGHT: SHEET 1 OF 1

SIZE DWG. NO. REV
C 40CB400067 A