

REVISIONS						
SHEET	ZONE	REV.	ECO	DESCRIPTION	DATE	APPROVED
1	ALL	A	50253	UPDATE DWG TO CURRENT FORMAT & STANDARDS	10/30/2018	HRC

**LATCH HARDWARE
(STAINLESS STEEL)**

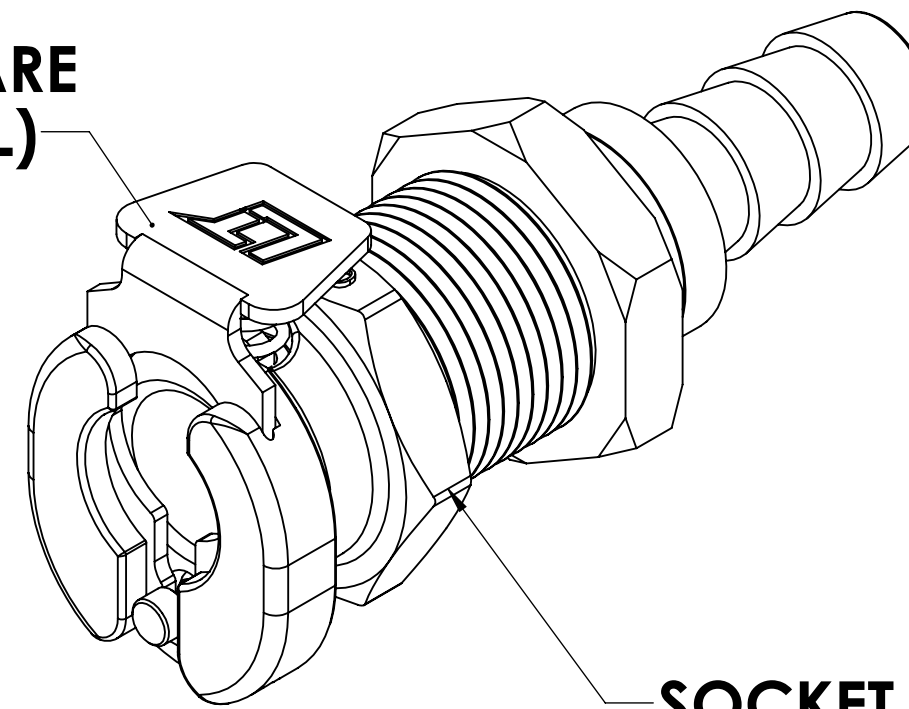

**SOCKET
(POLYPROPYLENE)**

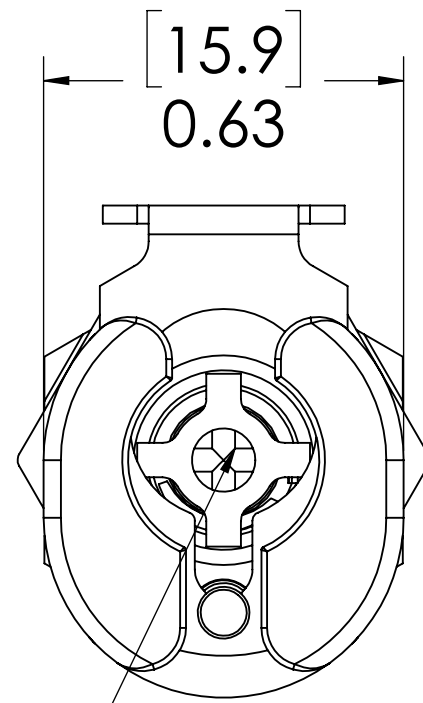

**VALVE
(POLYPROPYLENE)**

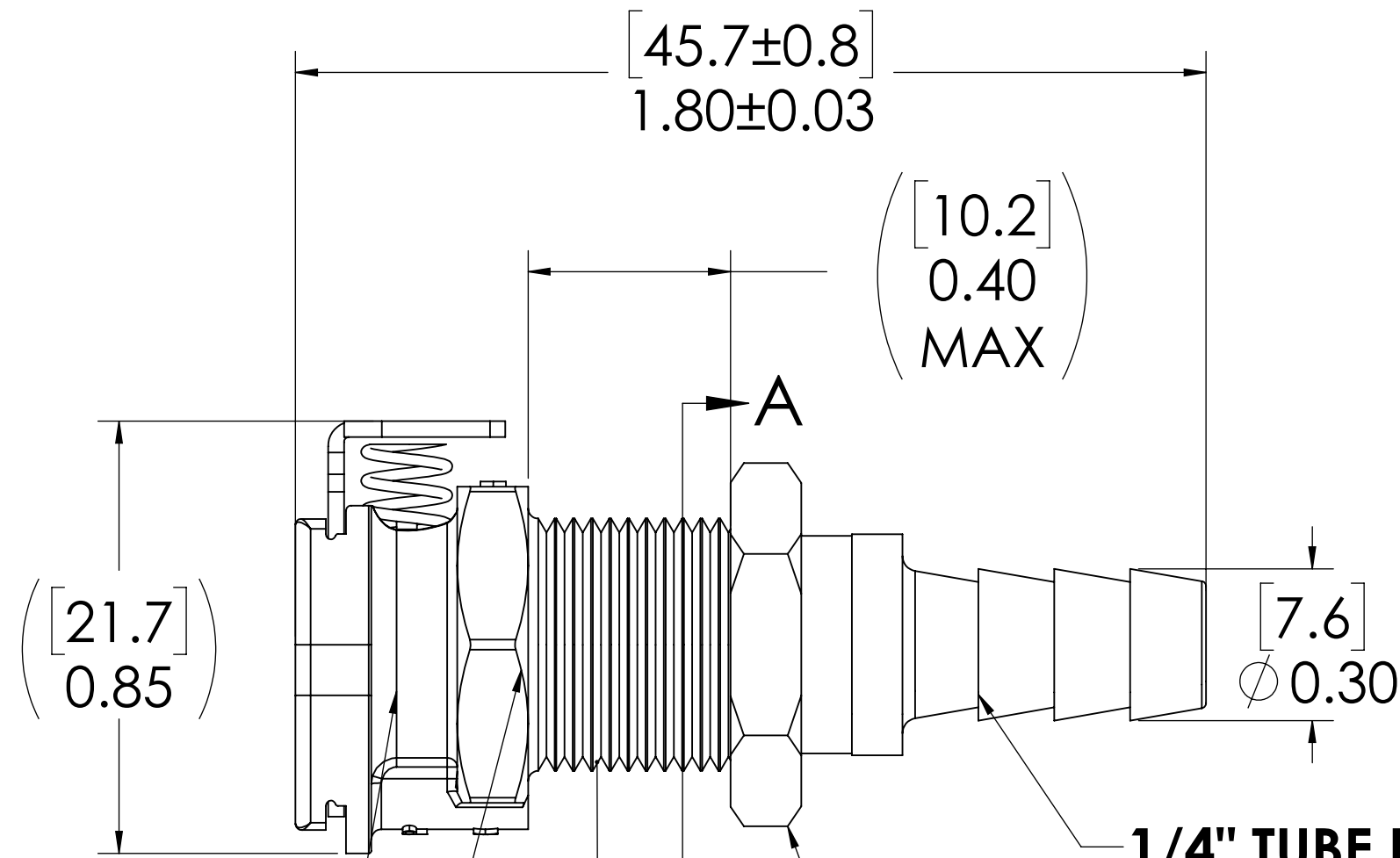

**VALVE SPRING
INTERNAL
(STAINLESS STEEL)**

**VALVE O-RING
INTERNAL
(EPDM)**

**PANEL NUT
(BRASS, NICKEL PLATED)
(PACKAGED SEPARATELY)**

1/2"-24 UNF THREAD

1/4" TUBE ID

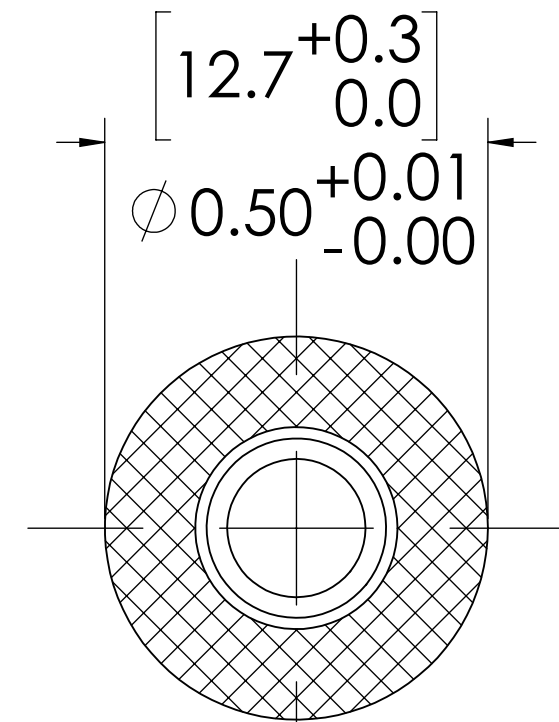

**PANEL OPENING
(SECTION A-A)**

NOTES:

- MATERIAL: POLYPROPYLENE
- COLOR: GREY
- O-RING MATERIAL: EPDM
- O-RINGS LUBRICATED WITH FOOD GRADE SILICONE OIL, 350 CST.

FOR REFERENCE ONLY

<small>UNLESS OTHERWISE SPECIFIED: DIMENSIONS ARE IN INCHES TOLERANCES: FRACTIONAL ± 1/32 ANGULAR: MACH ± 0.5 BEND ± 2 ONE PLACE DECIMAL ± 0.1 TWO PLACE DECIMAL ± 0.01 THREE PLACE DECIMAL ± 0.005 TWO PLACE DUAL (mm) [± 0.12]</small>	DRAWN	LMP	6/7/2018	 PART NO: 20PPV-SE3-04 DESCRIPTION: LinkTech 20PP Series, Panel Mt. Socket, Valved, 1/4" HB, Polypropylene
	CHECKED	HRC	6/7/2018	
	ENG APPR.	HRC	10/30/18	
	MFG APPR.	BDB	10/30/18	
PRODUCTION	LS	10/30/18	COMMENTS:	SIZE DWG. NO. REV C 20PP200088 A
<small>THE INFORMATION CONTAINED IN THIS DRAWING IS THE SOLE PROPERTY OF LINKTECH LLC. ANY REPRODUCTION OR DISCLOSURE IN PART OR AS A WHOLE WITHOUT THE WRITTEN PERMISSION OF LINKTECH LLC IS STRICTLY PROHIBITED.</small>			SCALE: NTS WEIGHT:	SHEET 1 OF 1