

| REVISIONS | | | | | | |
|-----------|------|------|-------|--|----------|----------|
| SHEET | ZONE | REV. | ECO | DESCRIPTION | DATE | APPROVED |
| 1 | ALL | A | 50253 | UPDATE DWG TO CURRENT FORMAT & STANDARDS | 7/9/2018 | HRC |

**LATCH HARDWARE
(STAINLESS STEEL)**

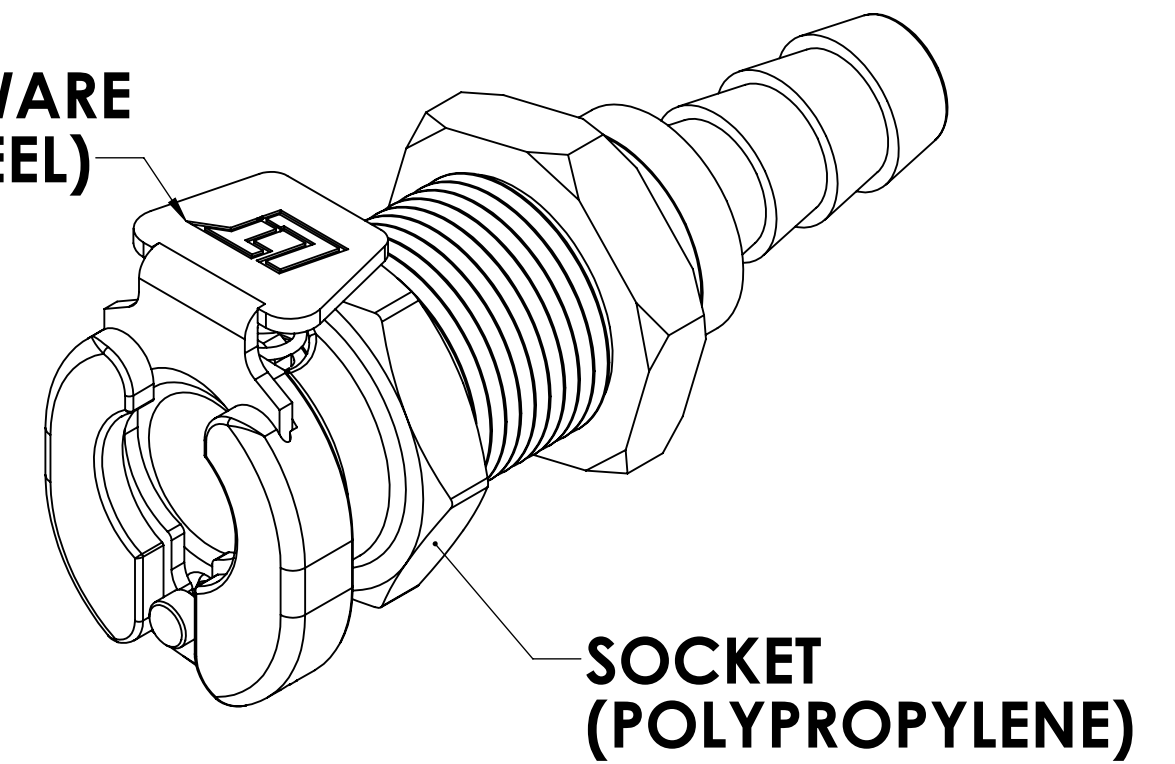

**SOCKET
(POLYPROPYLENE)**

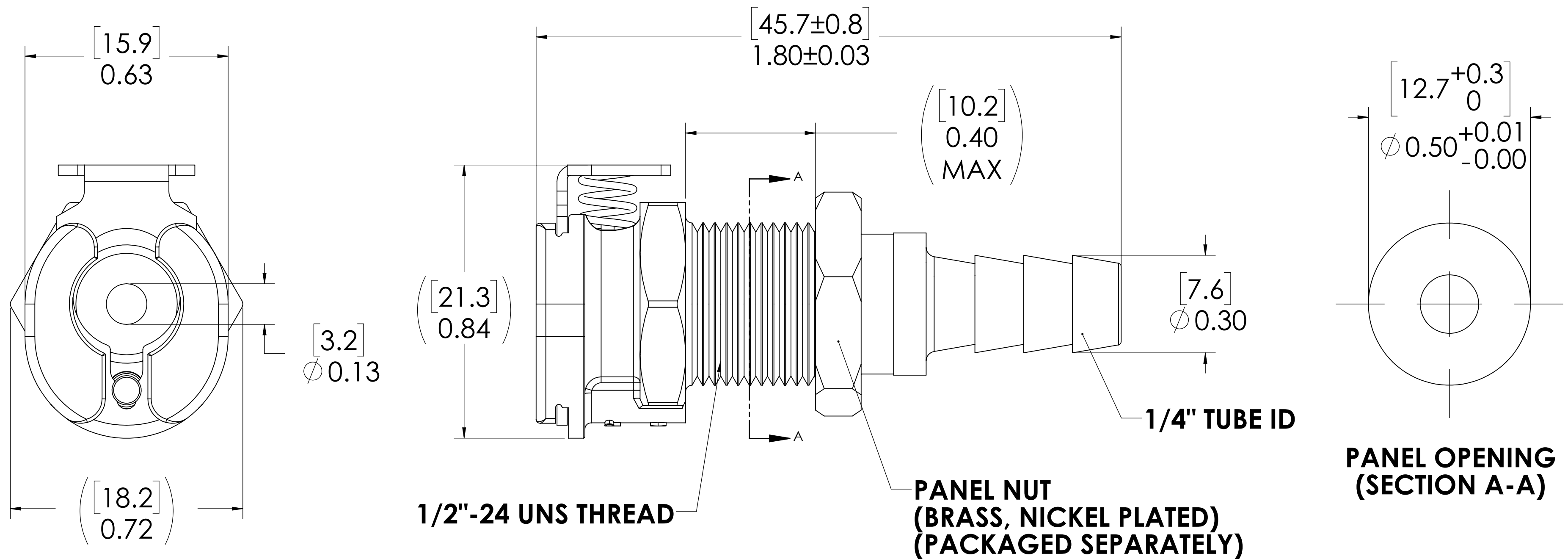

**PANEL OPENING
(SECTION A-A)**

FOR REFERENCE ONLY

NOTES:

- MATERIAL: POLYPROPYLENE
- COLOR: ALMOND

| UNLESS OTHERWISE SPECIFIED: | | NAME | DATE | LINKTECH AGENCIES LIMITED |
|--|--|------------|--------------|---|
| DIMENSIONS ARE IN INCHES TOLERANCES: FRACTIONAL ± 1/32 ANGULAR: MACH ± 0.5 BEND ± 2 ONE PLACE DECIMAL ± 0.1 TWO PLACE DECIMAL ± 0.01 THREE PLACE DECIMAL ± 0.005 TWO PLACE DUAL (mm) [± 0.12] | | DRAWN | ER 08-01-17 | |
| PROPRIETARY AND CONFIDENTIAL | | CHECKED | HRC 08-01-17 | |
| THE INFORMATION CONTAINED IN THIS DRAWING IS THE SOLE PROPERTY OF LINKTECH LLC. ANY REPRODUCTION OR DISCLOSURE IN PART OR AS A WHOLE WITHOUT THE WRITTEN PERMISSION OF LINKTECH LLC IS STRICTLY PROHIBITED. | | ENG APPR. | HRC 7/9/18 | |
| | | MFG APPR. | BDB 7/9/18 | |
| | | PRODUCTION | LS 7/9/18 | DESCRIPTION: LinkTech 20PP Series Panel Mt. Female, Non-Valved, 1/4" HB, Molded Almond Color, Polypropylene |
| | | COMMENTS: | | SIZE DWG. NO. REV C 20PP200178 A |
| | | | | SCALE: NTS WEIGHT: SHEET 1 OF 1 |