

REVISIONS						
SHEET	ZONE	REV.	ECO	DESCRIPTION	DATE	APPROVED
1	ALL	A	50109	CONVERTED DRAWINGS TO SOLIDWORKS	8/25/14	SCD
1	E-2, E-6	A	50109	CHANGED END TERM FROM C350 TO C11418	8/25/14	SCD
1	ALL	B	50242	PIN, PIN SPRING & 2017 FORMAT UPDATE	8/18/2017	HRC

**LATCH HARDWARE,
(STAINLESS STEEL)**

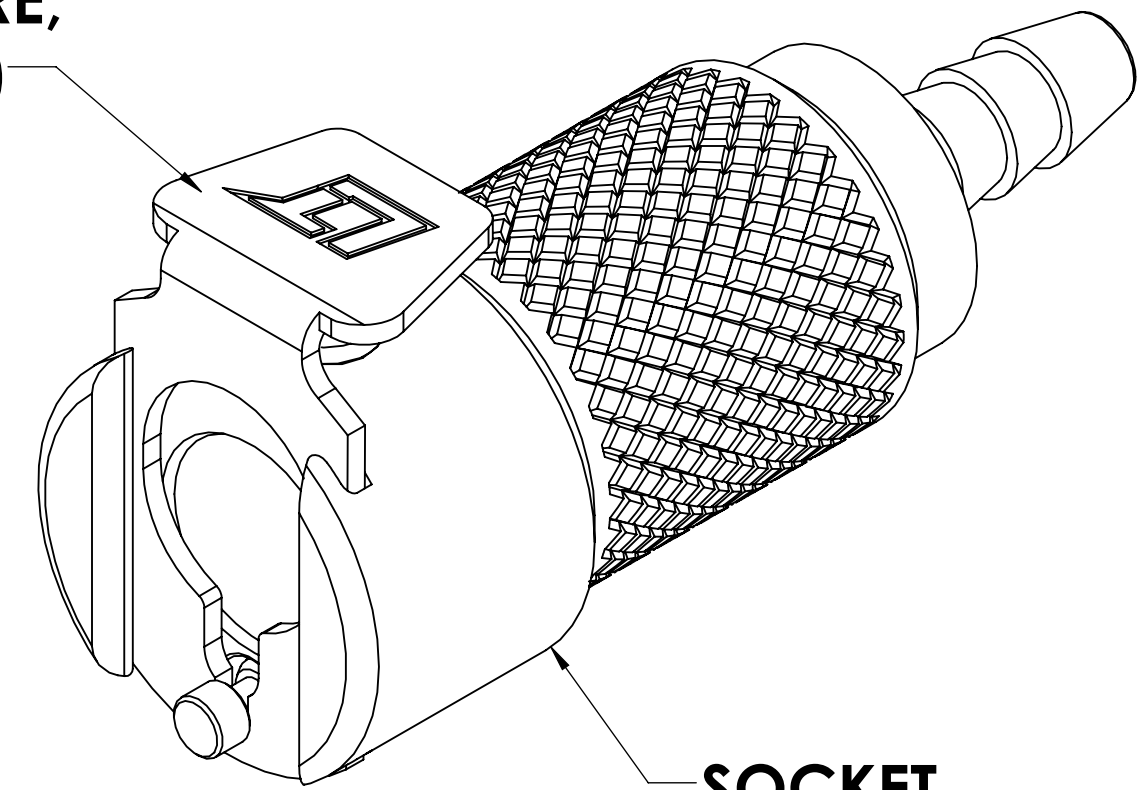

**SOCKET,
(BRASS, NICKEL AND
CHROME PLATED)**

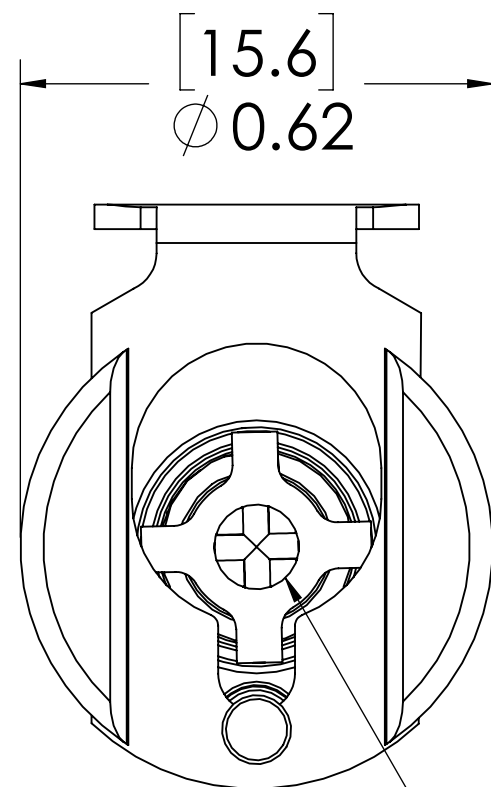

**VALVE,
(ACETAL)**

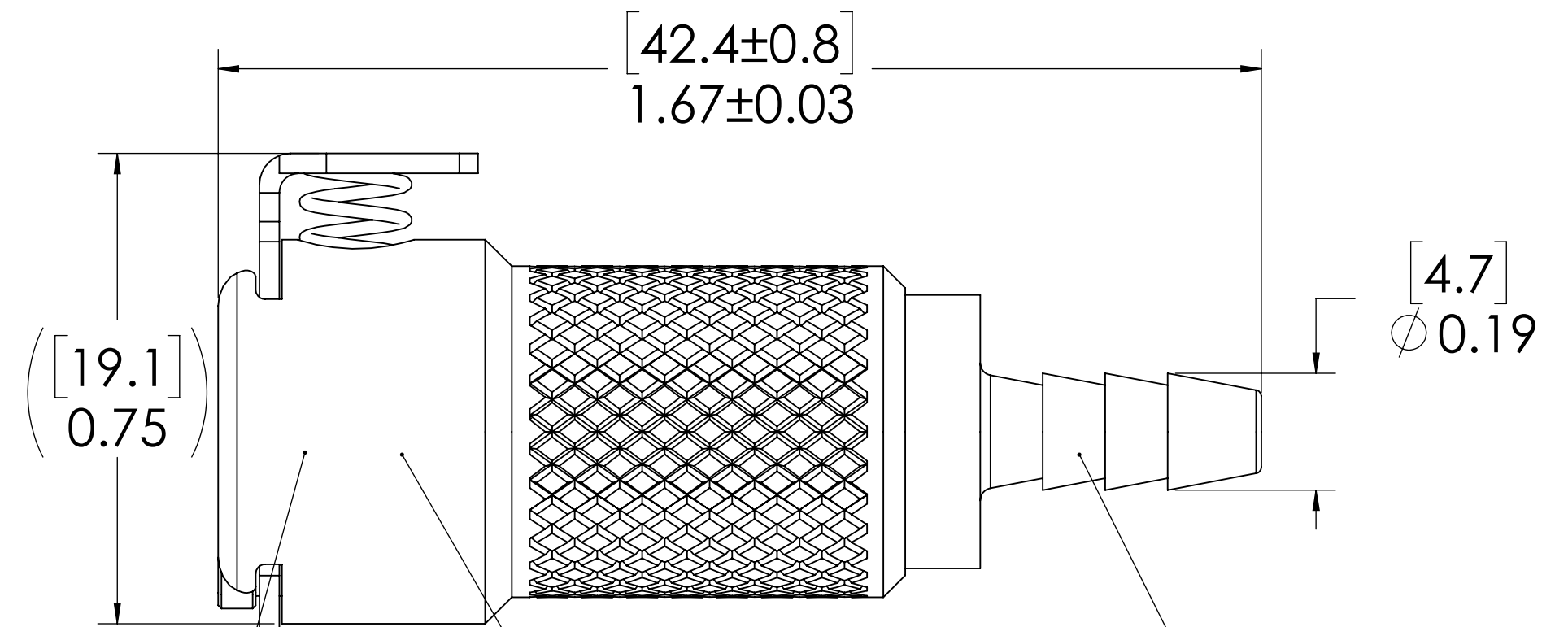

**VALVE SPRING,
INTERNAL
(STAINLESS STEEL)**

**VALVE O-RING,
INTERNAL
(BUNA-N)**

1/8" TUBE ID

NOTES:

- MATERIAL: BRASS
- FINISH: CHROME
- O-RING MATERIAL: BUNA-N
- O-RINGS LUBRICATED WITH FOOD GRADE SILICONE OIL, 350 CST.

FOR REFERENCE ONLY

<small>UNLESS OTHERWISE SPECIFIED: DIMENSIONS ARE IN INCHES TOLERANCES: FRACTIONAL ±1/32 ANGULAR: MACH ±0.5 BEND ±2 ONE PLACE DECIMAL ±0.1 TWO PLACE DECIMAL ±0.01 THREE PLACE DECIMAL ±0.005 TWO PLACE DUAL (mm) [±0.12]</small>	DRAWN	SCD	8/19/14	
	CHECKED	HRC	8/19/14	
	ENG APPR.	HRC	8/19/14	
	MFG APPR.	BDB	8/19/14	
<small>PROPRIETARY AND CONFIDENTIAL THE INFORMATION CONTAINED IN THIS DRAWING IS THE SOLE PROPERTY OF LINKTECH LLC. ANY REPRODUCTION OR DISCLOSURE IN PART OR AS A WHOLE WITHOUT THE WRITTEN PERMISSION OF LINKTECH LLC IS STRICTLY PROHIBITED.</small>	Q.A.	JJB	8/19/14	PART NO: 20CBV-SB2-02 DESCRIPTION: LinkTech 20CB Series Straight Female, Valved, 1/8" HB, Chrome Brass
<small>SIZE DWG. NO. REV</small>		<small>SCALE: NTS WEIGHT: SHEET 1 OF 1</small>		C 20CB200123 B