

REVISIONS						
SHEET	ZONE	REV.	ECO	DESCRIPTION	DATE	APPROVED
1	ALL	A	50253	UPDATE DWG TO CURRENT FORMAT & STANDARDS	10/4/2018	HRC

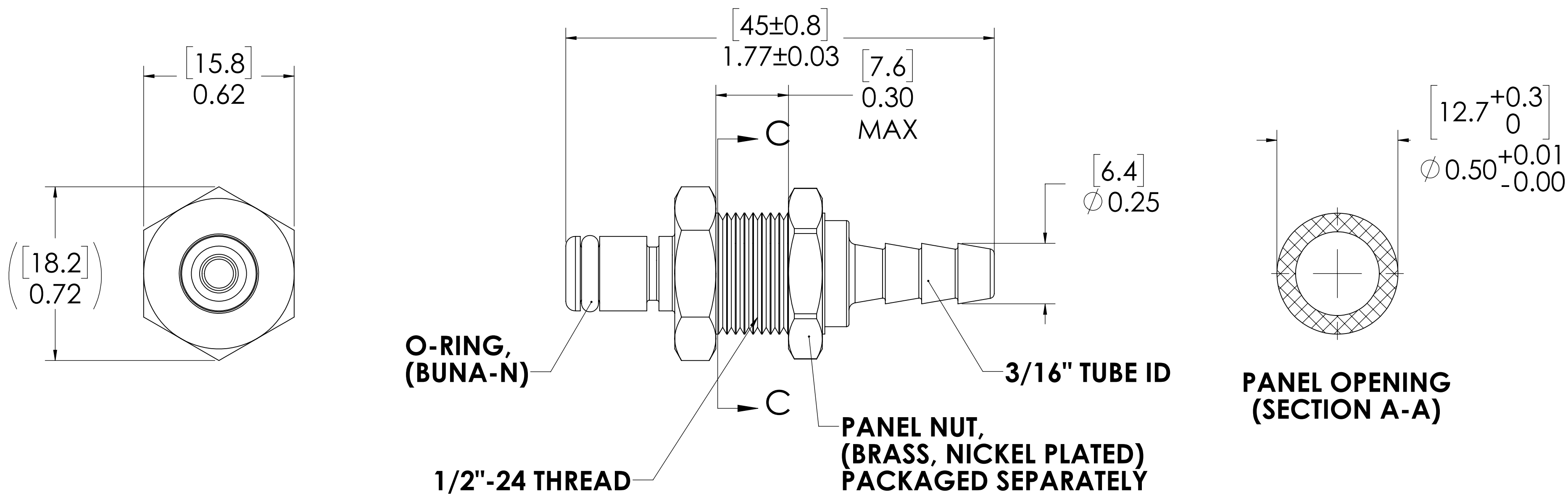
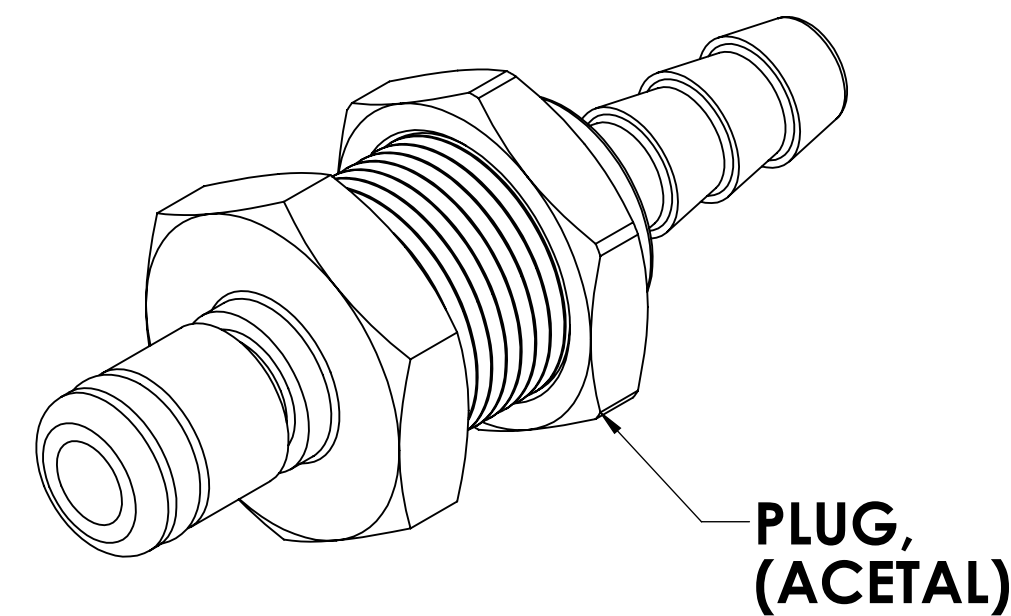

**NOTES:**

1. MATERIAL: ACETAL
2. COLOR: NATURAL WHITE
3. O-RING MATERIAL: BUNA-N
4. O-RINGS LUBRICATED WITH FOOD GRADE SILICONE OIL, 350 CST.

**FOR REFERENCE ONLY**

<small>UNLESS OTHERWISE SPECIFIED: DIMENSIONS ARE IN INCHES TOLERANCES: FRACTIONAL <math>\pm 1/32</math> ANGULAR: MACH <math>\pm 0.5</math> BEND <math>\pm 2</math> ONE PLACE DECIMAL <math>\pm 0.1</math> TWO PLACE DECIMAL <math>\pm 0.01</math> THREE PLACE DECIMAL <math>\pm 0.005</math> TWO PLACE DUAL (mm) <math>[\pm 0.12]</math></small>	DRAWN	ER	09-28-17	
	CHECKED	HRC	09-28-17	
	ENG APPR.	HRC	10/4/18	
	MFG APPR.	BDB	10/4/18	
PRODUCTION	LS	10/4/18		<b>PART NO:</b> 20AC-PB3-03 <b>DESCRIPTION:</b> LinkTech 20AC Series Panel Mt. Male, Non-valved, 3/16" HB, Natural Acetal
<small>PROPRIETARY AND CONFIDENTIAL THE INFORMATION CONTAINED IN THIS DRAWING IS THE SOLE PROPERTY OF LINKTECH LLC. ANY REPRODUCTION OR DISCLOSURE IN PART OR AS A WHOLE WITHOUT THE WRITTEN PERMISSION OF LINKTECH LLC IS STRICTLY PROHIBITED.</small>				<b>SCALE:</b> NTS   <b>WEIGHT:</b>   <b>SHEET 1 OF 1</b>