

REVISIONS						
SHEET	ZONE	REV.	ECO	DESCRIPTION	DATE	APPROVED
1	ALL	NC	50047	INITIAL RELEASE	6/11/2013	HRC
1	ALL	A	50253	2017 FORMAT UPDATE	7/11/2017	HRC
1	ALL	B	50253(2)	UPDATE DWG TO CURRENT FORMAT, INSPECTION DRAWING, & STANDARDS	5/7/2018	HRC

**LOCK SLEEVE
(ACETAL)**

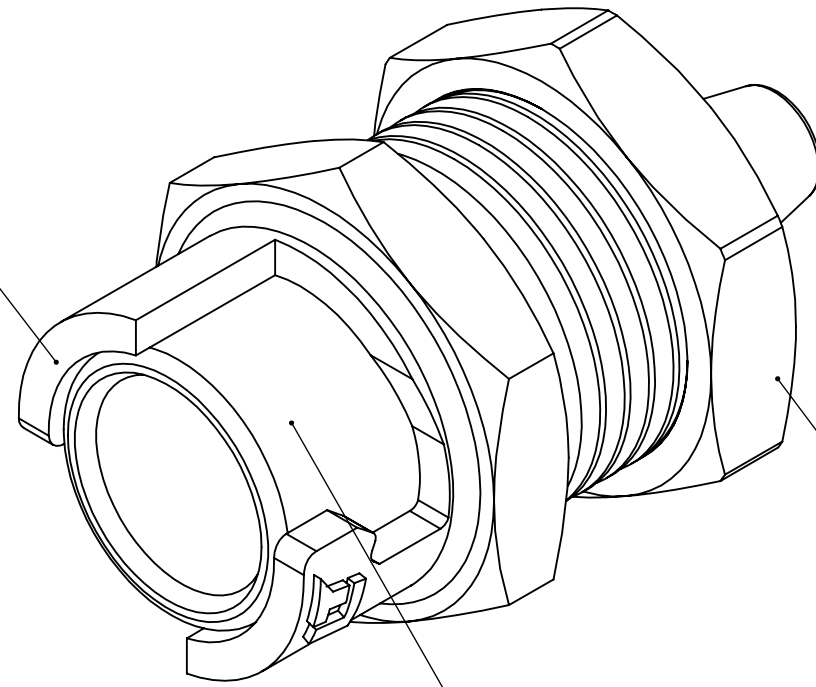

**PANEL NUT
(BRASS, NICKEL PLATED)
(PACKAGED SEPARATELY)**

**SOCKET
(ACETAL)**

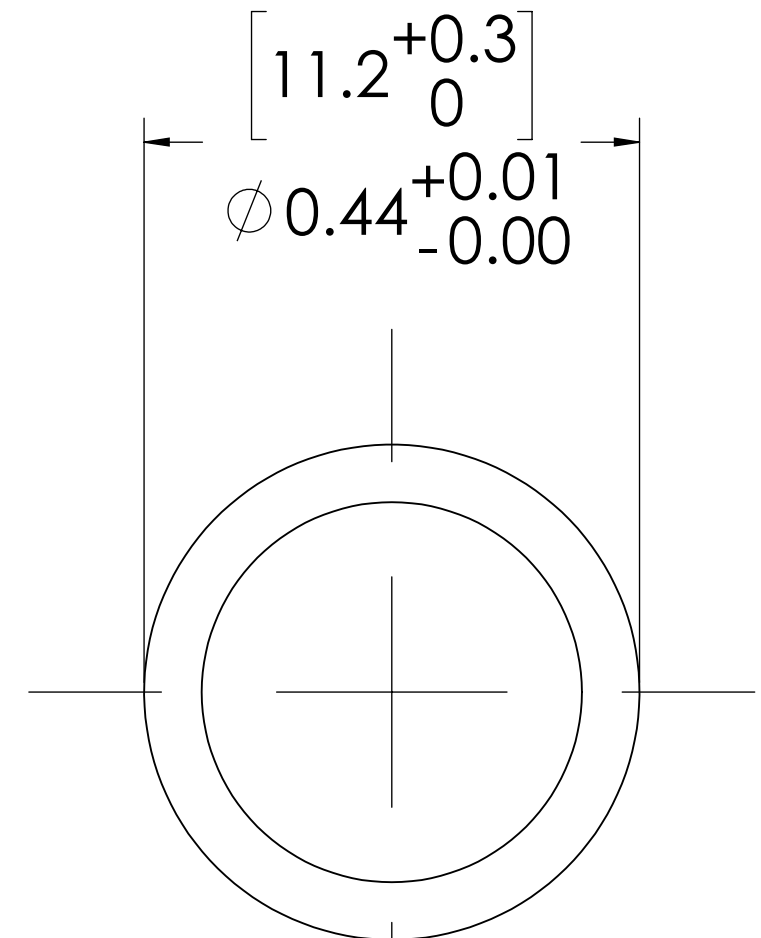
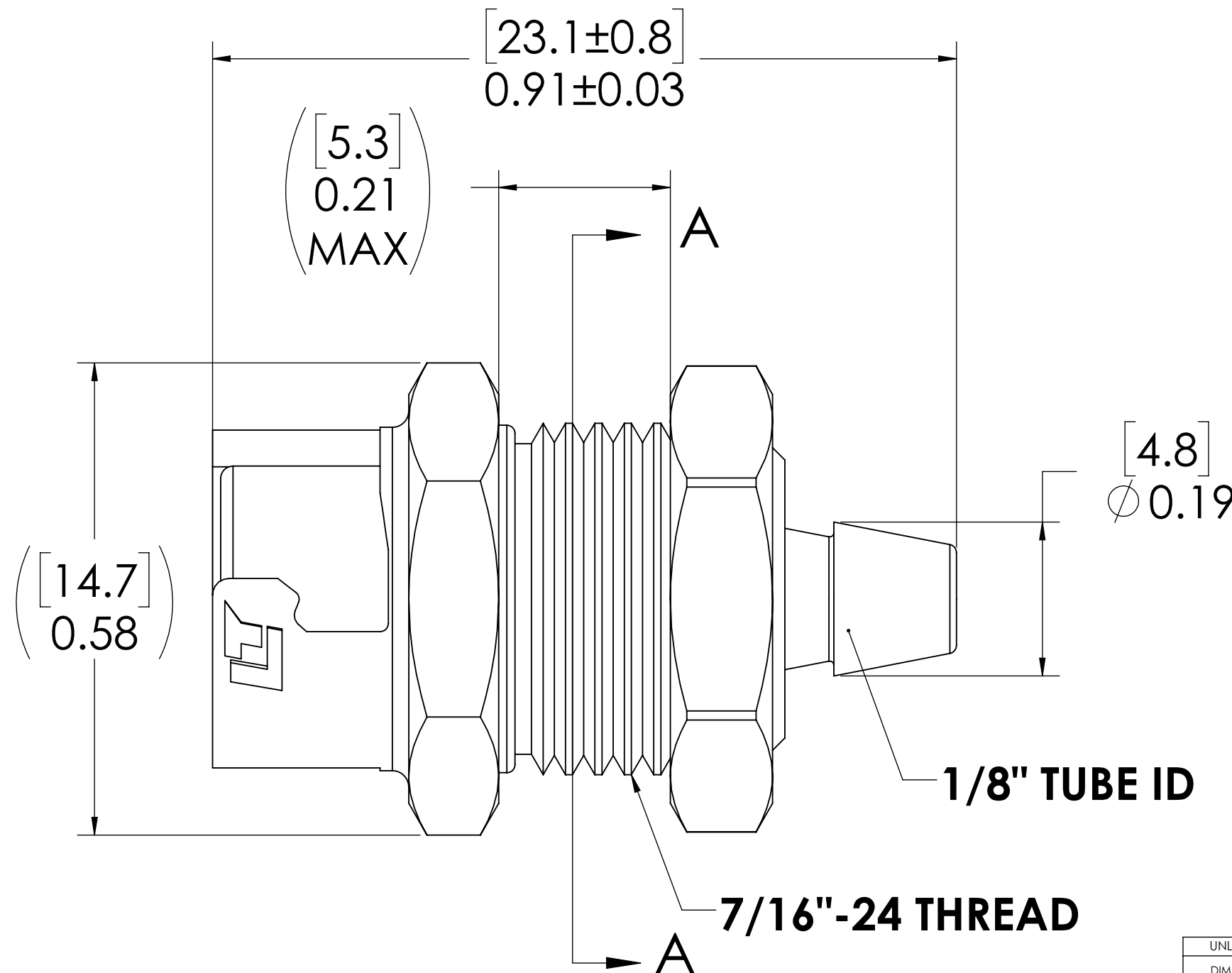
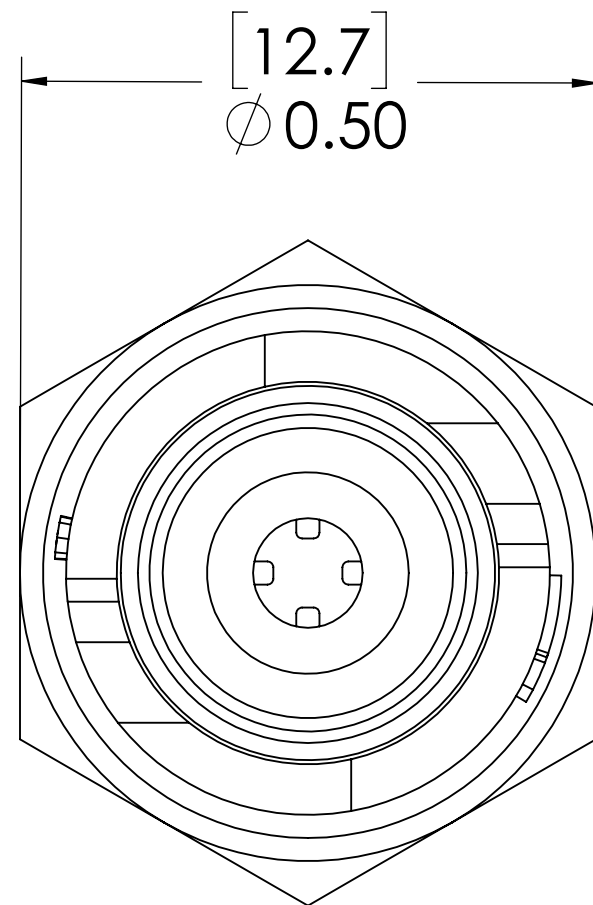

**PANEL OPENING
(SECTION A-A)**

FOR REFERENCE ONLY

NOTES:

- MATERIAL: ACETAL
- COLOR: NATURAL WHITE

<small>UNLESS OTHERWISE SPECIFIED: DIMENSIONS ARE IN INCHES TOLERANCES: FRACTIONAL ± 1/32 ANGULAR: MACH ± 0.5 BEND ± 2 ONE PLACE DECIMAL ± 0.1 TWO PLACE DECIMAL ± 0.01 THREE PLACE DECIMAL ± 0.005 TWO PLACE DUAL (mm) [±0.12]</small>	DRAWN	HRC	5/11/12	
	CHECKED	DHJ	5/14/12	
	ENG APPR.	HRC	5/7/18	
	MFG APPR.	BDB	5/7/18	
<small>PROPRIETARY AND CONFIDENTIAL THE INFORMATION CONTAINED IN THIS DRAWING IS THE SOLE PROPERTY OF LINKTECH LLC. ANY REPRODUCTION OR DISCLOSURE IN PART OR AS A WHOLE WITHOUT THE WRITTEN PERMISSION OF LINKTECH LLC IS STRICTLY PROHIBITED.</small>	PURCHASING	RK	5/7/18	PART NO: 10AC-S3-02
<small>COMMENTS:</small>				DESCRIPTION: LinkTech 10AC Series, Panel MT Socket, Non-Valved, 1/8" HB
SIZE	DWG. NO.	REV		
C	10AC100027	B		
SCALE: NTS	WEIGHT:	SHEET 1 OF 1		