

M144



REVOLVING HANDLE WITH SCREW AND NUT

Material:

Reinforced polyamide.
Oils and greases resistant.

Surface:

Satin.

Colour:

Black (RAL 9011).

Inserts:

- (1) Threaded black- oxide steel screw
TCCE DIN 912
- (2) Threaded black- oxide steelnut DIN 934.

SPECIAL REQUEST:

- It is possible to supply inserts in different materials, on request and for quantities.
- It is possible to supply colours as shown in the table at pag. M-29, on request and for quantities.

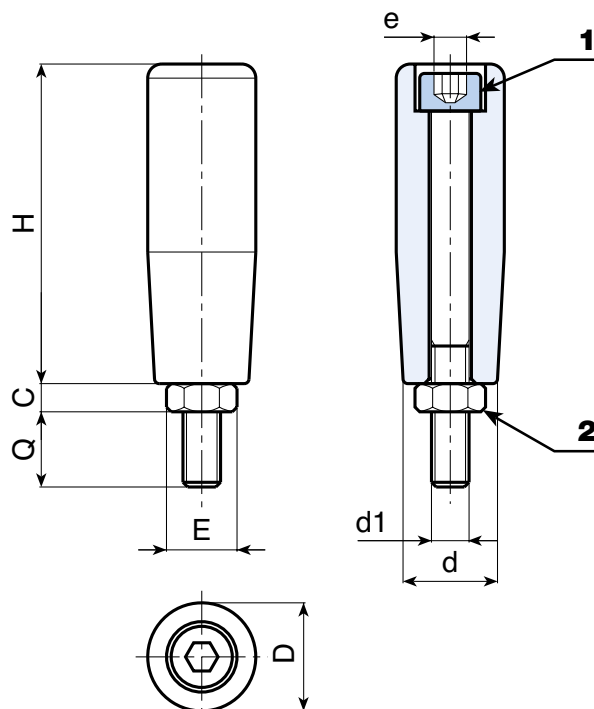

art.	H	D	d	c	E	e	d1 6g	Q	g
M14450.TM06X0901	49	20	17	5	10	05	M06	09	30
M14450.TM08X1401	49	20	17	6,5	10	05	M08	14	32
M14460.TM08X1501	59	21	19	6,5	13	06	M08	15	56
M14470.TM08X1601	68	23	20	6,5	17	08	M08	16	68
M14470.TM10X1601	68	23	20	8	17	08	M10	16	92
M14480.TM10X1501	79	25	22	8	17	08	M10	15	110
M14490.TM12X1701	89	28	24,5	7	19	10	M12	17	150